

8-Pack Special Instrumentation

Special instrumentation includes equipment which is not included in other sub-groups.

This includes:

Acoustic Sensors: for breakdown location

PMTs: for breakdown location and possible interlock

Temperature monitoring: Of high power RF components

Thermal RF power measurement: Independent calibrated power measurement

Estimated Materials and Shops costs are included. Labor is presumed to be some combination of: Josef Frisch, Doug McCormick, Keith Jobe, Marc Ross, however time has not been allocated, and priorities relative to other projects have not been set.

Table 1: Estimated system costs (M+S)

System	Cost
Acoustic	35,000
Photomultiplier system	12,000
Temperature Measurement	6,500
Thermal power measurement	11,000
Total Special Instrumentation	64,500

Acoustic Sensors

Function: Used to monitor and localized breakdown signals

Priority: High (have proven invaluable in locating breakdowns in NLCTA).

Description: Pulse heating of RF structures generates acoustic signals which have been measured at frequencies from ~ 1 KHz to ~ 1 MHz, limited by the detection equipment. Pulse heating and measurable acoustic output is produced by normal RF pulses, and has been found to increase by a factor of ~ 10 for "breakdown" pulses.

Measurement of the start-time and power high frequency acoustic signal (100KHz - 1MHz) allows localization of a breakdown event to approximately 1 cm. This measurement provides information independent of RF measurements of breakdowns.

For non-breakdown pulses, the acoustic power has been found to be linear in the RF power in a structure. Acoustic sensors allow uncalibrated, but linear and reproducible measurements of the RF power in system components. This information can be used in addition to the RF diagnostics to understand the system operation.

System Description: The acoustic sensors must be located $< \sim 3$ M from the amplifiers. The amplifiers provide a differential output capable of driving 100 Ohm twisted pair. Twisted pair trunks are used to transport the signals to the instrumentation racks. A balanced to unbalanced, 100 - 50 Ohm transformer is used to adapt the signals to 50 Ohm coax. EPICS 10Ms/s VME digitizers are used to record the signals for off-line processing in Matlab.

Interface / Treaty Points: The sensors are mounted to the high power RF components by the special instrumentation group. The data from the digitizers is collected by software (software group).

Status: The system described is essentially a duplicate of the acoustic sensor system in use at NLCTA. That system is providing useful data, but is still being developed.

Remaining work: Detailed costing, design, coordination, manpower allocation.

Acoustic Sensors (continued).

Sensors: ITC 9080 or SLAC-built sensors. (~\$40/sensor)

Amplifier: SLAC 8 channel NIM, variable gain. Twisted pair output. ~\$3000/module)

Patch Panel: Commercial (Blackbox JPN090A) Cat 5 to 4x25 pair UTP converter \$300/module

Transformer Panel: SLAC 24 channel balanced 100 Ohm to 50 Ohm balanced ~\$1000/module

Transient Digitizer: Joeger VTR812/10 10Ms/s, 12 bit, 8 channel. \$4500/ module

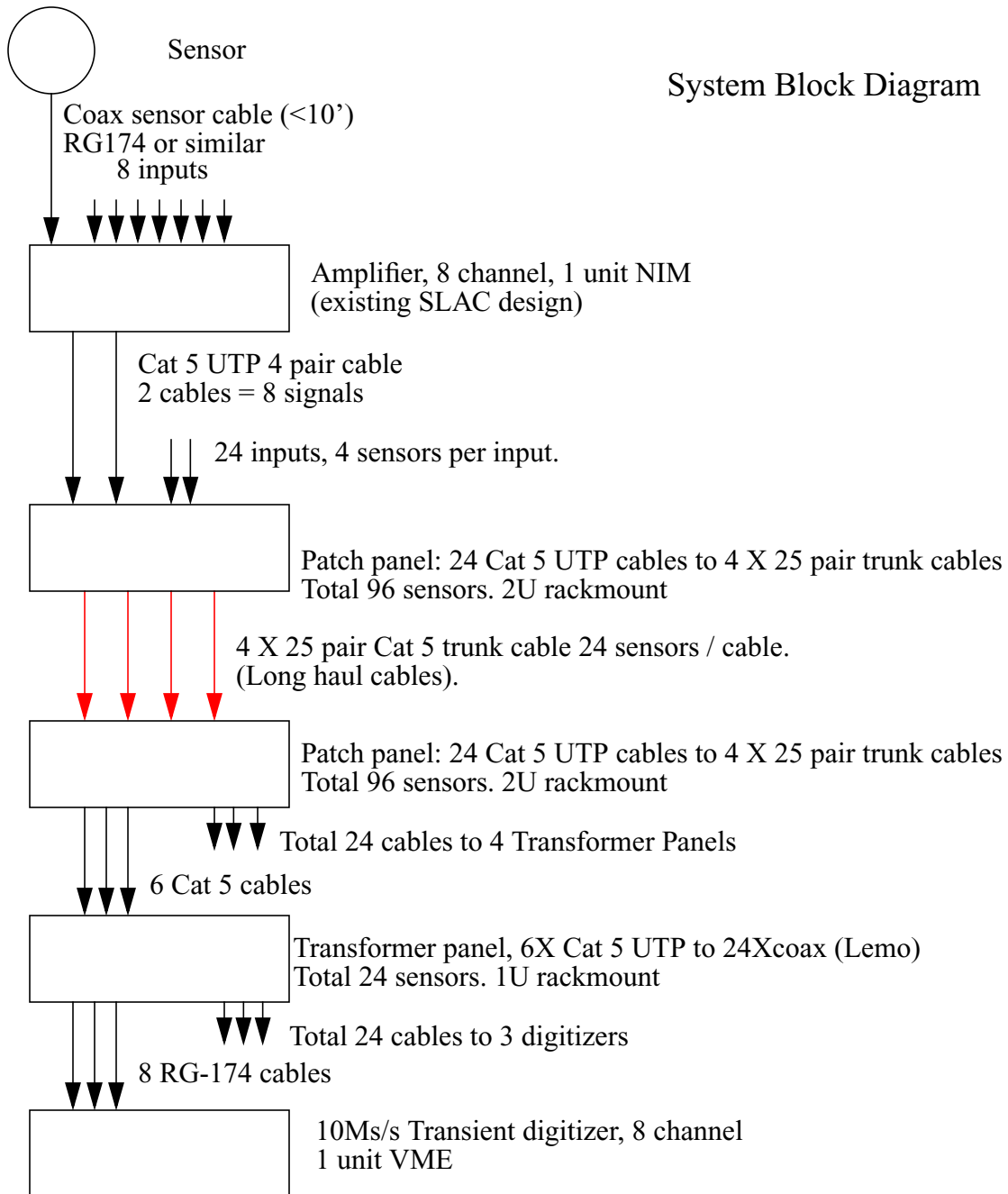

Acoustic Sensors (continued)

A full “system” contains 96 channels, in the following units:

Sensors: 96
NIM Amplifiers: 12
Input Patch Panel: 1
Trunk Cables: 4
Output Patch Panel: 1
Transformer Panel: 4
VME digitizers: 12

Any subset of the system can be installed.

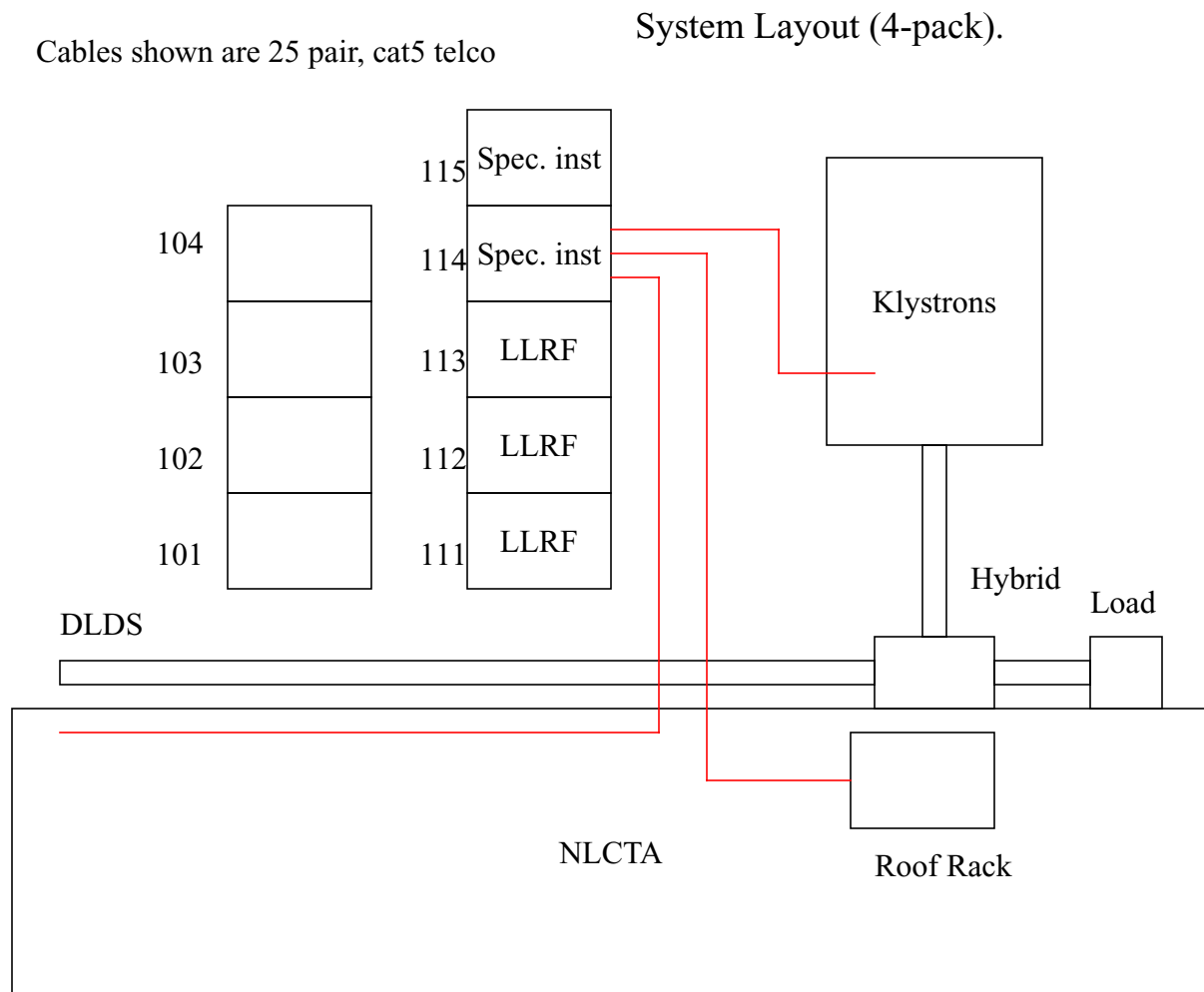

Acoustic Sensors (continued)

A total of 24 sensors is assumed for 4-pack. 8 are located at the super-hybrid, 8 at the end of the DLDS line, and 8 at the klystrons. The location and number of sensors used will be adjusted as needed.

Table 1: Acoustic Sensor Components and Costs

Item	Location	Cost	N	Total Cost
Sensors	Super hybrid		8	
Sensors	DLDS		8	
Sensors	Klystrons(?)	40	8	960
Amplifiers	(see above)	~3000	3	9000
NIM crates	(see above)	2300	3	6900
Patch Panels	(see above)		3	
Patch Panels	Inst. Rack	200	1	1200
Trunk Cables**	(see diagram)	300	3	900
Cable Install		(GUESS)		500
Transformer	Inst. Rack	~1000	1	1000
Digitizer	Inst Rack	4500	3	13500
Misc cables, etc				1000
Total				~35000

*NIM crates costed here, also be used for other diagnostics.

** Estimated cost with connectors

Software: Software will be essentially identical to the NLCTA acoustic sensor system. Data base work to duplicate that system will be required.

Installation: Long haul cables, interface panels, NIM crates must be installed. Sensors and sensor cables will be installed by the special projects group. Note that it may be mechanically impractical to install a NIM crate near the klystron / modulator tank. For 4-pack the crate can be installed in spare space in racks 120/121.

PMTs.

Function: Used to look for radiation from RF breakdowns.

Priority: High

Description: Photomultiplier tubes (possibly with scintillators) are mounted near high power RF components. X-rays generated during RF breakdowns will be detected and their amplitude and timing measured. Optionally, a discriminated output can be used as a fast RF interlock.

System Description: Hamamatsu photosensor modules (PMT with integrated HV supply) are used to eliminate the need for the high voltage system. If needed, NIM PMT amplifiers are installed in the NIM crates near the PMTs. The amplified signals used directly, and with discriminators. The outputs from the discriminators can be used to interlock the RF if desired.

The signals are measured with 100Ms/s Transient digitizers, of the same type use for the LLRF system. The recorded signals can be processed to measure integrated signal and rise time.

The PMT system in NLCTA was not effective in locating breakdowns due to radiation from high energy accelerated beam from breakdowns. In 8-pack, there is no accelerated beam, and performance is expected to be much better.

Interface / Treaty Points: The PMTs are mounted on the high power RF structures by the special instrumentation group. The data from the digitizers is read by software (software group).

Status: This system is very similar in design to PMT systems in use at NLCTA and around SLAC. No significant R+D is required.

Remaining work: Detailed costing, design, coordination, manpower allocation.

PMTs (continued)

PMTs: Integrated modules, Hamamatsu H5773 or similar \$700

PMT amplifiers: 20dB, 12 channel NIM units. Existing parts (if needed).

Linear Fan in / Fan out: 4:4, 4 channel NIM unit. Existing

Discriminator: 8 channel, NIM unit, Existing

Gate / Delay Generator: 2 or 4 channel, TTL out, Existing.

Transient Digitizer: SIS3300, 8 channel, 12 bit 100Ms/s. (same as for LLRF) \$4500

DAC: VMIVME 4132 (or similar - same as used for LLRF). ~\$3000

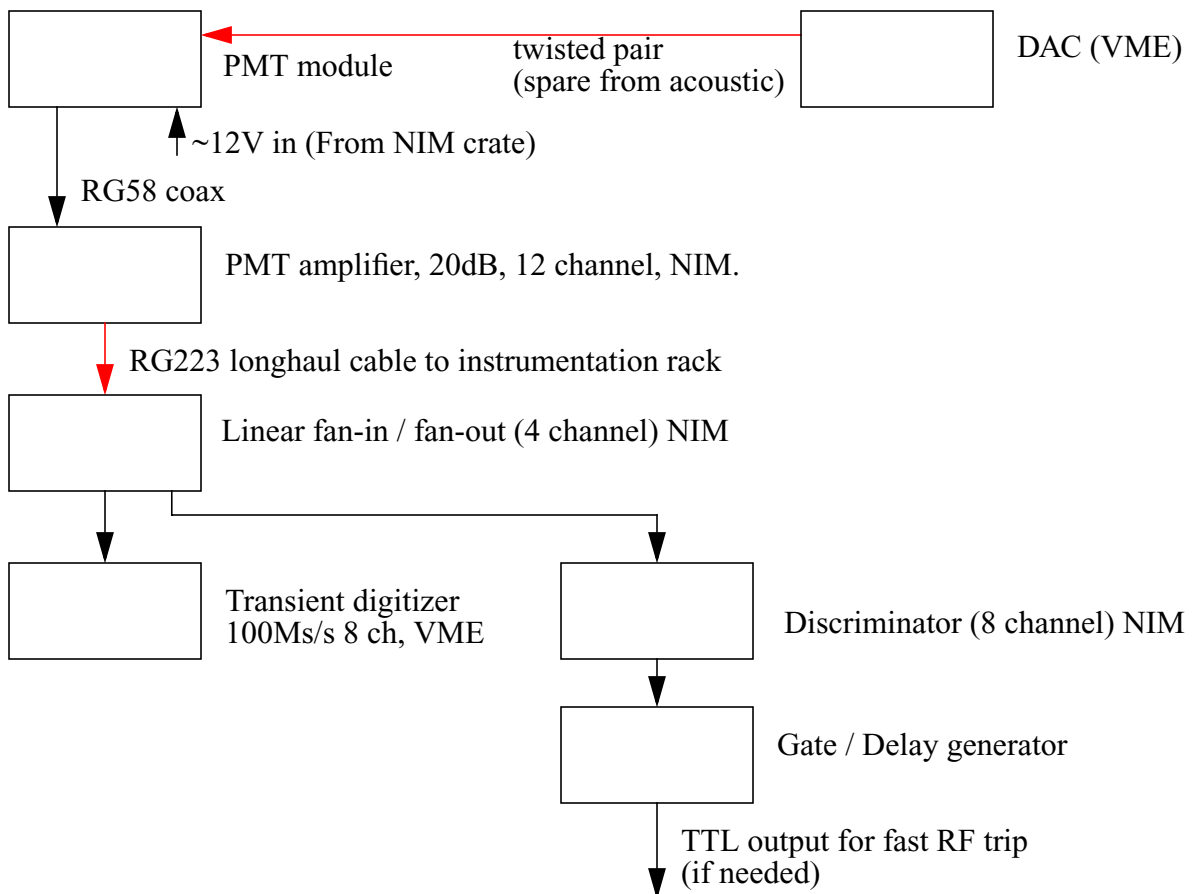

PMTs (continued).

RG223 is used for signal cable. Cables should be run to patch panels on racks (or to floor for DLDS end).

Analog gain control is sent using spare twisted pair channels from the acoustic sensor system.

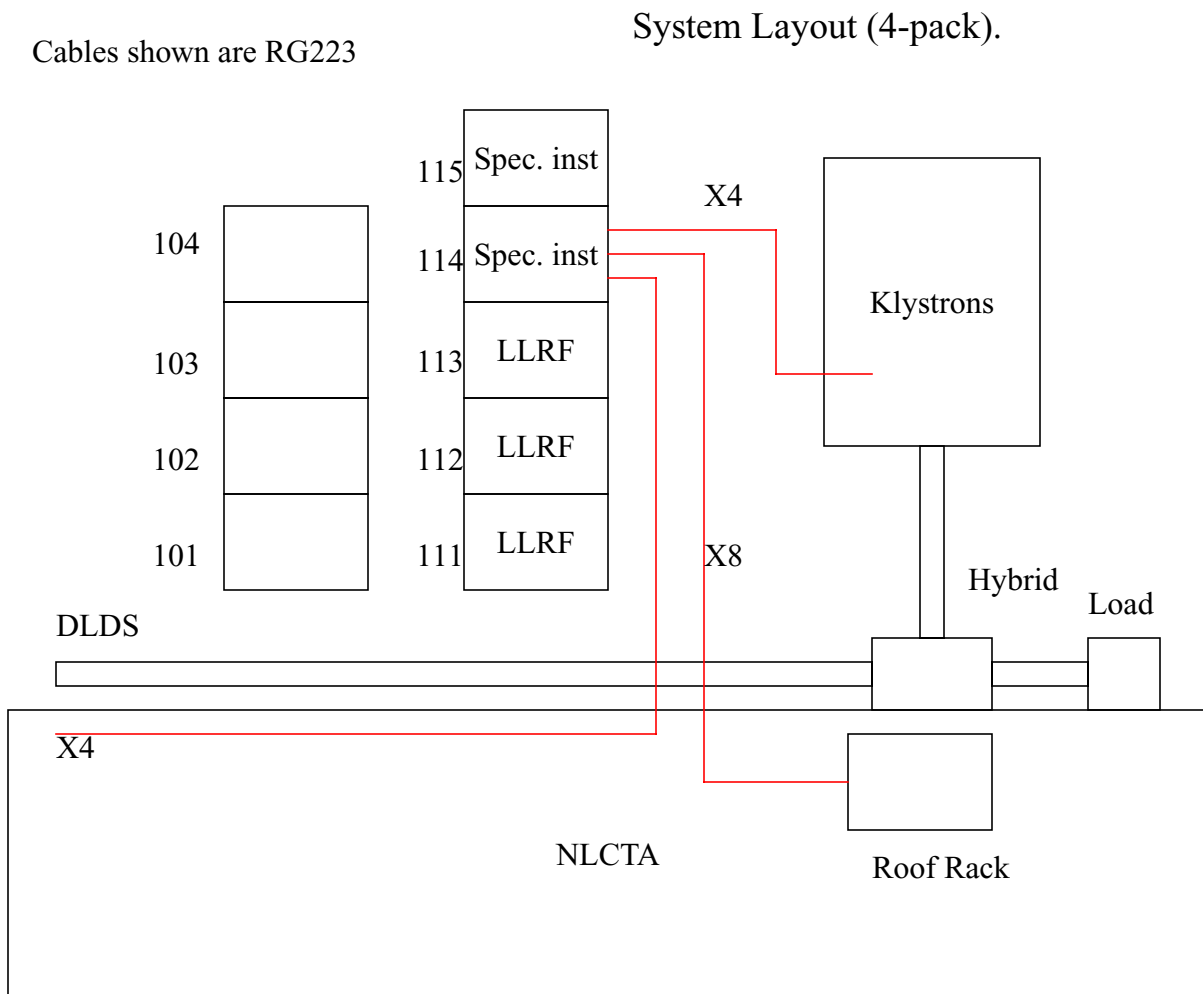

PMTs (Continued)

A total of 6 sensors (initially) is assumed. 2 are assumed located at the super-hybrid. 2 near the klystrons, and 2 at the end of the DLDS lines.

Item	Location	Cost	N	Total Cost
PMT modules	super hybrid		2	
PMT modules	klystron		2	
PMT modules	DLDS end	700	2	4200
PMT amplifiers	where needed		2 (est)	existing
Linear fifo	Inst. Racks		2	existing
Discriminator	Inst Racks		1	existing
Gate / delay	Inst racks		1	existing
NIM crate *	Inst racks		1	2300
Transient digi-tizer	Inst racks		1	~4500
Long haul cable		\$1.5/ft.	1000	1500
cable installation		(GUESS)		1000
Misc cables				1000
Total				\$12000

*Nim crate also used for other special instrumentation

Temperature

Function: Measure RF component temperatures

Priority: High

Description: Thermocouples are used to monitor RF component temperatures. This will allow identification of over-heating components, and can be used in feed-forward for phase stabilization.

System Description: Standard SLAC thermocouples, thermocouple reference plane, and a SAM are used.

Interface / Treaty Points: Thermocouples are connected to the RF components. The SLC software (software group) is used to read the SAM

Status: This is a standard SLAC thermocouple installation, no engineering required.

Remaining work: Detailed costing, coordination, manpower allocation.

Components and Locations:

Thermocouples: Total = 32

Klystron power combiners: 2

Klystron spare 4

Super Hybrid 2

DLDS pipes: 1/20' each pipe, total of ~16

End of DLDS pipes: 2

Spare near loads: 6

Thermocouple Reference plane: Located near any CAMAC crate

SAM: Located near any CAMAC crate

Item	Location	Cost	N	Total Cost
thermocouples	see above	~\$.25/ft.	32x100'	800
installation		GUESS		1500
Reference plane	Near Sam			~2000
SAM	free slot			2000
Total				6300

Thermal Power Measurement

Function: Provide a calibrated measurement of the RF power.

Description: An accurate measurement of the thermal power removed by the water to the RF loads is made. This should provide a <5% absolute accuracy RF power measurement.

System Description: The waveguide loads collect a maximum of 54KW (at 120Hz, full power) with 38 GPM of water - corresponding to a temperature rise of 5 °C. A measurement for 60Hz, 50% power is desirable, requiring a (differential) temperature measurement of 0.025 °C, a flow measurement to <3%, and an air dissipation of <1Kw (achievable with insulation). The inlet water temperature to the structure varies by approximately 5 degrees C over long timescales.

Temperature measurement: The SLAC thermocouples track to ~0.1 degree C, not quite sufficient for this measurement. Type K thermocouples produce approximately 40uV/°C, so a differential measurement would be required to read 1 microvolt. A HP3458 voltmeter (existing) has a <1 microvolt long term stability, and can be used for this measurement. The readout can be manual, or through GPIB to the control system.

Flow measurement: A turbine flow meter (Omega FTB1206) provides 1% accuracy for flows up to 45 Gpm. An independent measurement with a variable area flowmeter (Omega FL8305AB) provides a ~3% accuracy measurement.

Substitution heater: A water heater in series with the loads can be used provide an independent calibration of the power measurement. A 30KW, 480V (Omega NWH series) water heater can be used with RMS current (clamp on) and volt meters to provide a ~2% absolute accuracy power calibration.

Interface / Treaty Points: The water connections for the flowmeter must be compatible with the water system. The flowmeter and heater must mounted to the support structure. The precision voltmeter must be interfaced to GPIB.

Status: Only a basic block diagram exists.

Remaining work: All, except for basic design.

Thermal Power Measurement Costs:

Item	Location	Cost	N	Total Cost
flow meter	Near load	\$2200	1	2200
Voltmeter	Inst racks	existing		existing
Thermocouples				minimal
Water heater		~3500		3500
Mech installation		GUESS		2000
Electrical installation		GUESS		2000
Voltmeters, etc				1000
Total				~\$11000