

Laser Wires for Linear Colliders

Josef Frisch August 29 2001
1st Laser Wire Mini-Workshop, Tsukuba Japan

Comparison of Laser Wires with other Profile Diagnostics

Phosphor Screens: Single pulse full profile measurement. High sensitivity, but poor (~10 μ m) spatial resolution. Invasive. Degrade with time. Can be damaged.

Transition Radiation monitors: Single pulse full profile measurement. Good resolution (~2 μ m). Invasive. Can be damaged.

Synchrotron Monitors: Single pulse profile measurement. Poor resolution (>10 μ m). X-ray based systems may have good resolution - not well investigated. Difficult at high energy.

Synchrotron Interferometers: Good resolution (~2 μ m). Multi-pulse measurement. Need to de-convolve beam information.

Conventional wire scanners: Good resolution (~1 μ m). Multi-pulse measurement. Can be damaged by beam. Partially invasive.

Laser Wires: Good resolution (~0.5 μ m for round beams, few micron for elliptical beams). Multi-pulse measurement. Gives X,Y integrated scans. Partially invasive.

Laser Interferometers: Excellent resolution (few nm?). Need to de convolve beam data.

Laser Wire Wavelength Requirements

A Gaussian laser beam propagates as $\sigma_\gamma^2(x) = \sigma_{\gamma 0}^2 \left(1 + \left(\frac{x\lambda}{4\pi\sigma_{\gamma 0}^2} \right)^2 \right)$ where $R_l = 4\pi \frac{\sigma_{\gamma 0}^2}{\lambda}$ is the Rayleigh Range of the beam. If we wish to scan an electron beam of sizes σ_x, σ_y , in the Y direction it is reasonable to choose $R_l = \sigma_x$. If we want the size of the laser beam to add ~10% in quadrature with the size of the electron beam, we want $\sigma_\gamma = \frac{1}{3}\sigma_y$. Solving for the

wavelength this gives: $\lambda_{max} = \frac{4}{9}\pi \frac{\sigma_y^2}{\sigma_x}$

Machine	sigma x microns	sigma y microns	Required Wavelength: microns
TESLA (Diagnostic section 250GeV)	120um	7um	0.67 um
JLC 500GeV	10	3	1.3 um
NLC 500GeV	10	1.25	0.22 um
NLC 1TeV	7.5	0.9	0.15 um

Beam scan for 7 x 120 micron (TESLA) beam

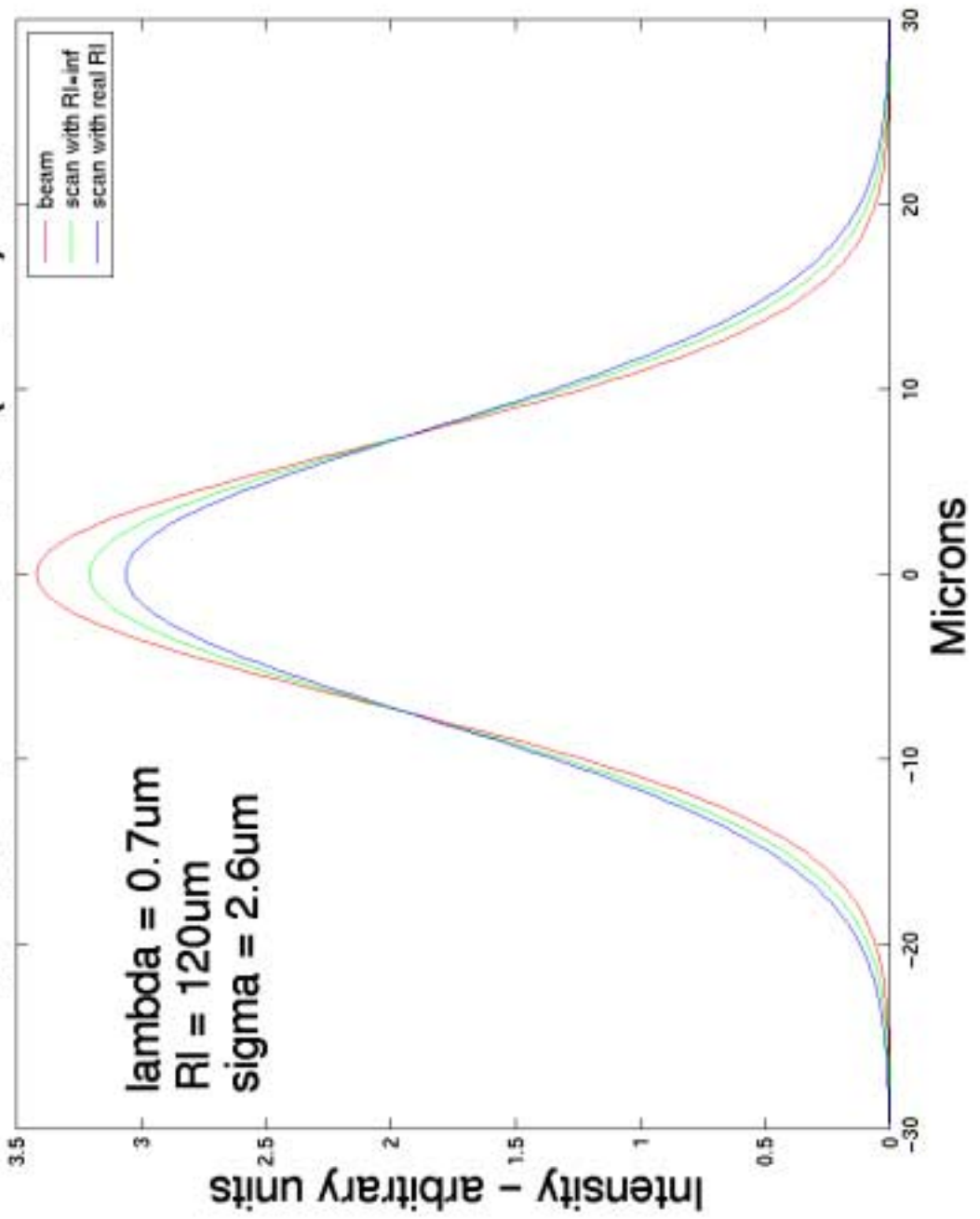

Beam scan for .9 x 7.5 micron (NLC) beam

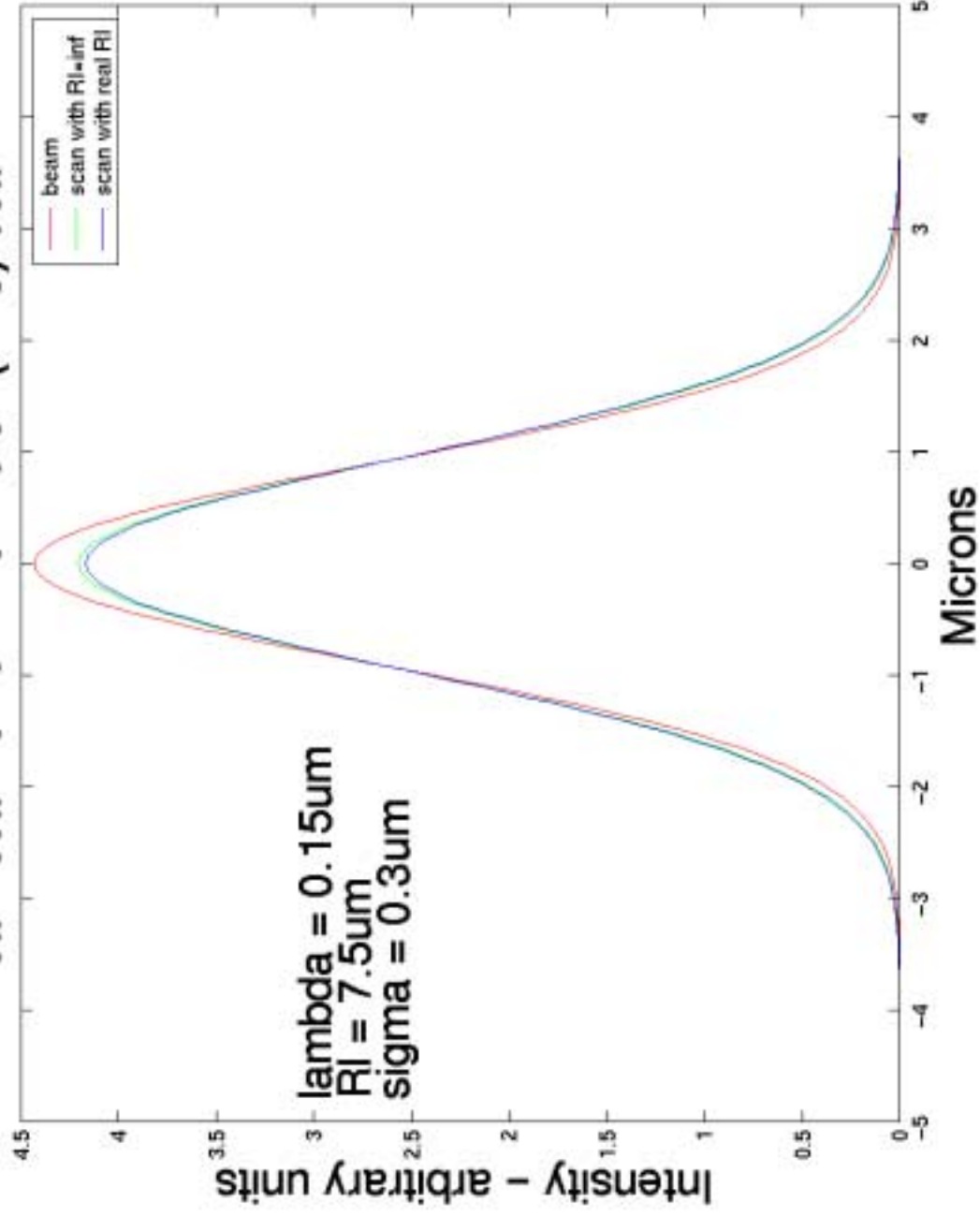

Beam scan for .9 x 7.5 micron (NLC) beam

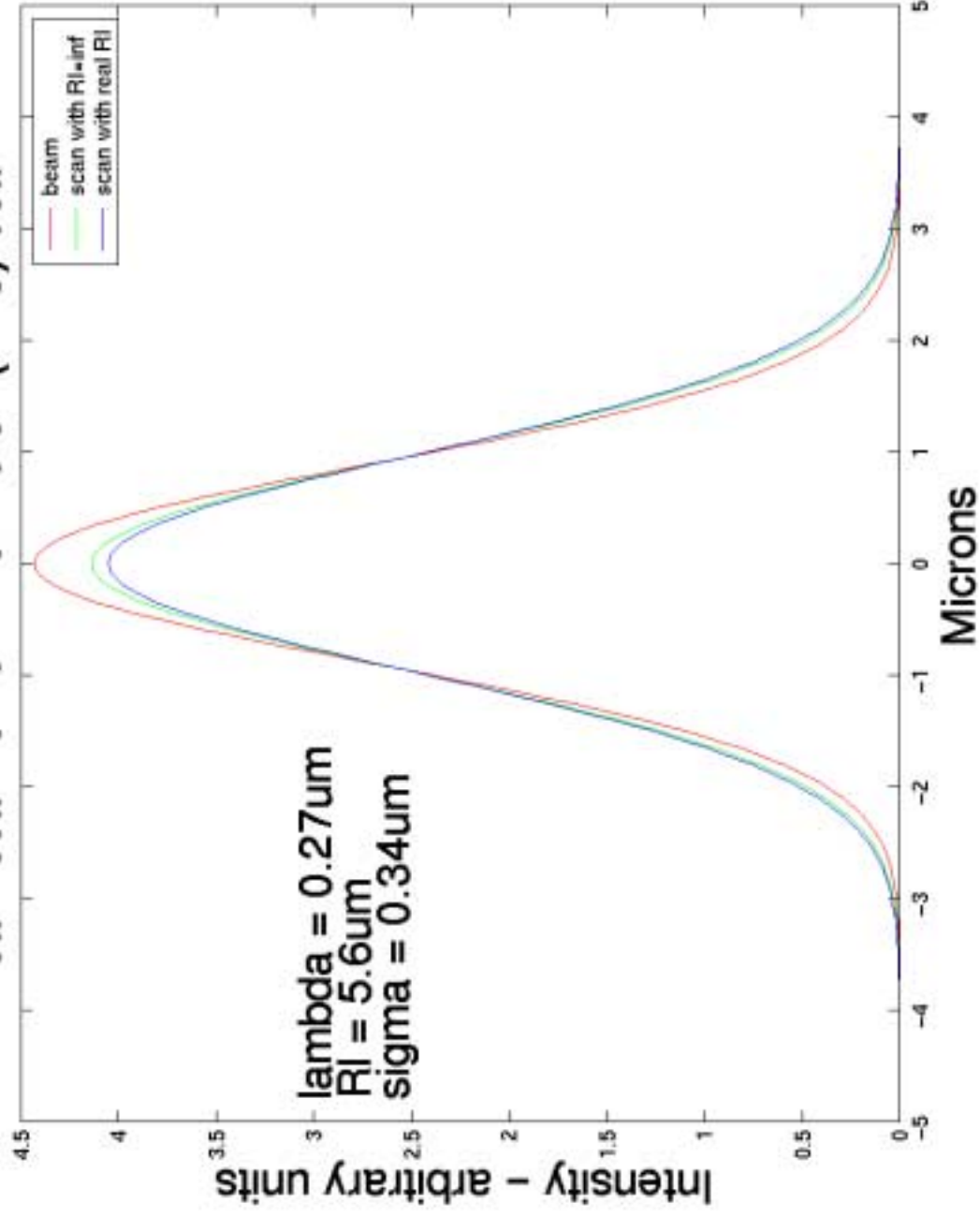

Laser Wire Power Requirements

Cross Section is $\sim 10^{-24} \text{cm}^2$. For $10^{10} e^-$, in $d=10 \mu\text{m}$ spot, scatter 10^{-3} photons per incident optical watt. (Scattering goes as $1/d$).

It is probably reasonable to assume $\sim 10\%$ of degraded electrons can be counted.

Pulsed Systems

If we want $\sim 10^3$ detected photons / bunch, we need approximately 10MW laser power for a 10 micron beam.

This allows scanning of a pulse profile at one machine cycle per scan point.

CW systems

For a CW system, at 1 second per scan point, and with a 1MHz single bunch repetition rate (damping ring), we need an intracavity power of: $\sim 10\text{W}$ for a 10 micron beam.

Linear Colliders - Injector Beam Parameters

Parameter (at entrance to DR)	NLC/JLC	TESLA (DC/RF gun)
Bunch Charge	$1.2 \times 10^{10} e^-$	$2 \times 10^{10} e^-$
Normalized Emittance (edge) mm-mr	100	45 / 10
Number of bunches	95	2820
Bunch Spacing	1.4nsec / 2.8nsec	337ns
Energy	1.98 GeV	5 GeV
Spot size at Linac exit (10M beta function)	0.5mm	0.2mm / 0.1mm
Single pulse density e^-/cm^2	1.5×10^{12}	$1.6 \times 10^{13} / 6.4 \times 10^{13}$
Approximate thermal time constant for Be*	1.5msec	0.7msec / 0.2msec
Multi pulse density in thermal time constant	1.4×10^{14}	$3.3 \times 10^{16} / 3.8 \times 10^{16}$
Density in carbon wire time constant**	1.4×10^{14}	$4.5 \times 10^{16} / 1.8 \times 10^{17}$

* Based on thermal diffusion over spot size.

** Approximately 1 millisecond Based on thermal emission at 2500°C, 4µm wire.

Be Damage limit $\sim 3 \times 10^{15} e^-/cm^2$. C damage limit $\sim 9 \times 10^{15} e^-/cm^2$

Injector Laser Wire Requirements

The NLC / JLC injector beams appear to be safe for operation with Transition radiation monitors, or conventional laser wires.

NLC / JLC may use laser wires in the injector to allow non-invasive (with averaging) beam scanning. The large beam sizes will require high laser power for rapid measurements.

It appears likely that laser wires will be required for the TESLA injector (at least in the higher energy section), unless special diagnostic optics are installed.

Linear Collider Damping Ring Laser Wires

Rings have large average bunch rates: 50MHz for TESLA 300MHz for NLC / JLC

For comparison, the average linac rates are: 14KHz for TESLA, 11KHz for NLC / JLC

Due to the much higher beam duty factor, CW (resonant cavity) laser wires are attractive for Damping Rings.

For NLC / JLC (5um X 50um beam size, 1MHz repetition rate) need ~5W intracavity power for 1 second / scan point.

For TESLA (7um x 140um beam size, 17KHz single bunch rate), need 20KW intracavity power (probably not practical to use a CW laser wire for the TESLA ring).

Note: in TESLA ring straight sections beam is ~400 microns round. Very high laser wire powers would be required.

Laser wires for Linear Collider Main Linacs

Technical Issues - Low Energy

The low backscatter energy makes detection of degraded particles difficult.

At 2GeV, 2eV (green) incident photons, Compton edge is 120MeV. (6%).

Large spots (~100um) require large laser power.

Technical Issues - High Energy

Small and highly elliptical beams make spatial resolution difficult.

NLC 1TeV, Diagnostic section: 7.5um X 0.9um

NLC 500GeV Diagnostic section: 10um X 1.25um.

JLC 500GeV 10um X 3 um (?)

TESLA (Diagnostic Station, 250GeV) 120um X 7um

Note: Standard laser wires will not work for IP spot size monitors. It is not clear that even laser interferometers can measure nanometer spots.

Sample Laser Beam Requirements for Linear Colliders

Note: These numbers are the result of trade-off between complexity and performance and are a guide only. F# is chosen as $F = \frac{1}{2} \sqrt{\frac{R_l}{\lambda}}$ where the factor of 1/2 is an approximation to limit diffraction.

Machine	sx, sy	Type	s0 / Rl	lambda	Ppk	lens F#
NLC / JLC Injector	500um	Wire / Transi- tion	X	X	X	X
TESLA Injector	100- 200um	Pulsed	10/1200	1.06	100MW	17
NLC / JLC Damping ring	5/50um	CW	1.7/70	.532	10W	NA
TESLA Linac or Damp- ing Ring	7/120um	Pulsed	2.2/120	.532	10MW	8
JLC 500GeV	3/10	Pulsed	1/25	.532	3MW	2.5
NLC 1TeV	0.9x7.5	Pulsed	.3/7.5	.157	1MW	3.5

Resonant Cavity Laser Wires

Use a CW laser, with an optical resonant cavity with a narrow waist.

Can get power enhancement factors ~ 100 , maybe as high as 1000.

Can get waist sizes to \sim few microns.

For a symmetric cavity, where the Rayleigh length is short compared with the cavity

length, $\left(1 - \frac{L}{2R}\right) = \frac{R_l^2}{L^2}$. For small waists, very accurate absolute cavity length control is

required. Note that this is in addition to the $\Delta L \ll \frac{\lambda}{Q}$ Resonance stability condition.

If we plug in our nominal requirement of $R_l = \sigma_x$, and $\sigma_y = \frac{1}{3}\sigma_x$

NLC / JLC damping ring: Beam = 5x50um. Optical sigma = 1.7um. Wavelength = 0.5um. Gives $R_l=70$ um. For a 2cm Optical cavity length, this gives a length accuracy requirement of 0.25 Microns. Intracavity power should be ~ 5 Watts for 1 second / scan point.

Resonant Cavity Laser Wires - Other Issues

Optical Surface Figure: A near concentric (narrow waist) cavity is very sensitive to surface errors in the mirrors. These can be either manufacturing defects, or thermal distortions.

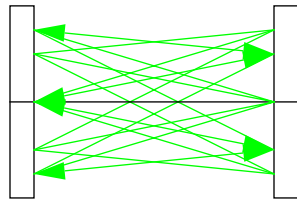

Stable Cavity
Ray samples entire mirror

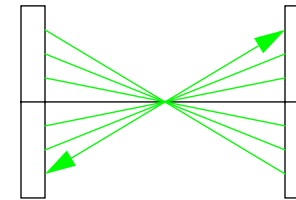

Concentric cavity
Optical ray samples single point

Radiation Damage: The mirrors must be mounted very close to the beam line. Coating losses must typically be $<100\text{ppm}$. Standard coatings are not radiation hard.

Vacuum Issues: Both the Damping Ring and the laser wire cavity mirrors need very good vacuums. Critical issues are different: Carbon is deadly for mirrors, fairly harmless to the damping ring. Hydrogen is a problem for the ring, but harmless to the mirrors.

Beam Scanning: It is desirable to be able to scan the optical beam rather than the electron beam. Changing the cavity center position while maintaining resonance is required.

Resonant Cavity Laser Wires - Feedback Systems

The sub-nanometer length stability tolerance requires active feedback. The feedback signal is the cavity transmission (or reflection) which is second order in the cavity length around the resonance point.

Very simplified system where the cavity length is modulated.

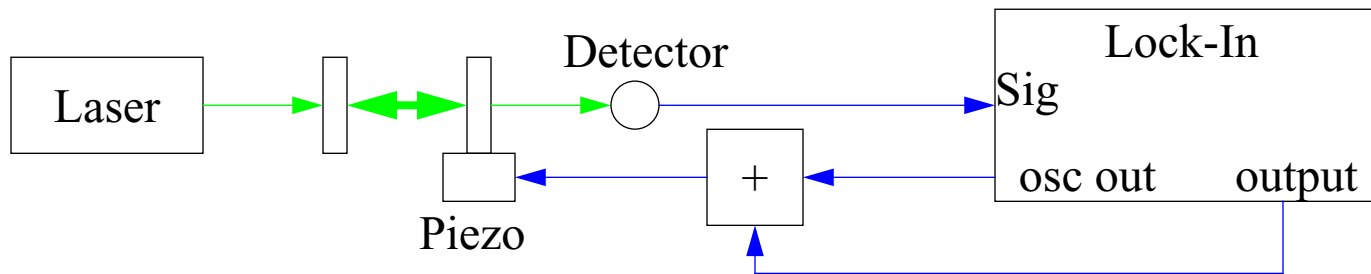

Very simplified system using sidebands on the laser

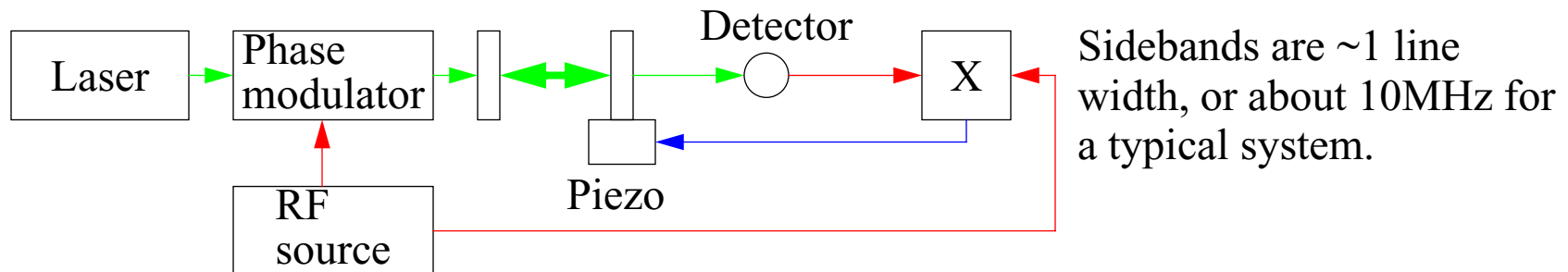

Resonant Cavity Laser Wires - Feedback Control Options

1. Can control the length of the optical resonator.

Laser design is very simple

Requires in-vacuum piezo-electric actuators

Significant in-vacuum complexity

2. Can fix the cavity length, and use wavelength tunable laser

Much simpler vacuum system.

More complex laser, but available as a commercial unit.

No ability to adjust cavity length for mode matching. Need to use “as built”

3. May be possible to put the laser material in a closed loop with the cavity - automatic tuning. (This idea has not been investigated in any detail).

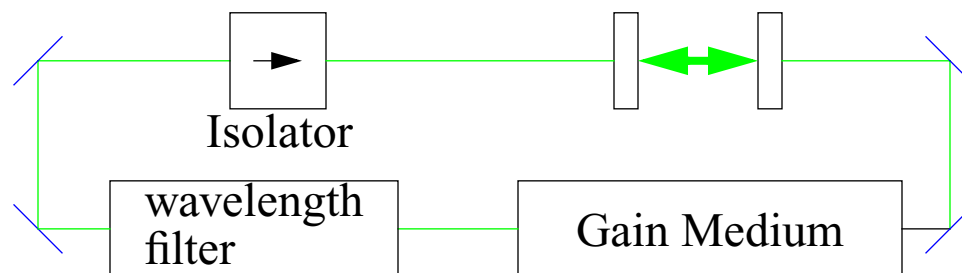

System only has gain at cavity resonances. Filter is used to limit the number of excited modes, possibly to 1 mode.

Pulsed Laser Wire Optical Focus Systems - Requirements

Diffraction limited optical spots

Variable $F^\#$ This allows operation with beams that are not at the design size or ellipticity. Probably want a factor of 4 total range in $F^\#$.

Remember: This is a diagnostic! It needs to work when the beam isn't at design.

High power operation: Peak powers of $\sim 10\text{MW}$ are expected.

Typical safe operating power levels are $\sim 5\text{GW}/\text{cm}^2$, and $1\text{J}/\text{cm}^2$ (for long lifetimes).

In order to reduce diffraction, we typically need a clear aperture $> 4x$ optical sigma.

This gives a required aperture of $r = \sqrt{8\frac{P}{\pi I}}$ where P is the total beam power (or energy), and I is the maximum allowed power (or energy) density.

For 10MW, 10ns (limited by energy density), this gives $r = .5\text{cm}$.

Note that if we allow a factor of 4 range in $F^\#$ this increase to $r = 2\text{cm}$.

Other High Power Issues for the Optical Focus

Nonlinear Damage: At high peak power and short wavelength, multi-photon damage can cause long term degradation of optics.

“Ghost” Reflections: In multi element lens systems, the reflection from a spherical lens surface can produce a tight focus in a different element. First and second order reflected foci must be eliminated in the design. Note that design tools (ZEMAX) can track ghost reflections.

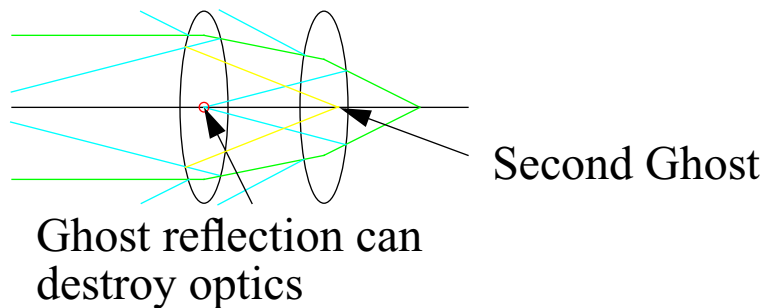

AR coatings still reflect $\sim 0.1\%$. After 2 reflections, a 10 micron spot is still damaging.

Air ionization: A high power focus in air will cause breakdown, and disrupt the beam. The lens must either operate in vacuum, or be designed with no intermediate (or first order Ghost) focus.

Laser wire Optical Focus Systems: Design Options

Cannot use standard lens designed for use in air: window produces aberration.

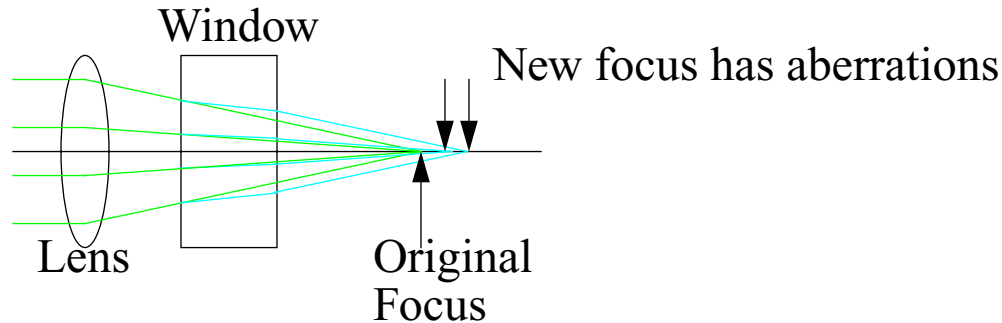

Conventional Multi-element lens: Allows re-image of spot to check for aberrations. Complex, many optical elements.

Lens / Reflector: Used for SLC laser wire. Better optical performance with few elements.

No re-image possible.

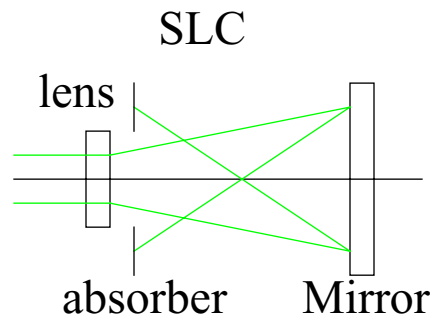

All reflective design

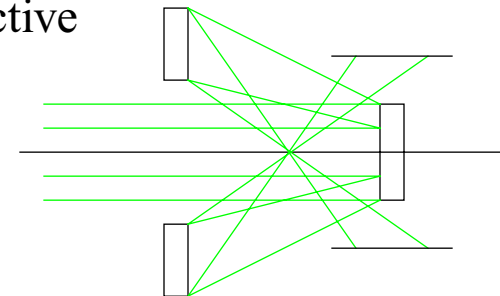

Laser Requirements for Pulsed Laser Wires

Wavelength: 0.5 micron OK for most applications. NLC small beams may require very short wavelength - 0.157um.

Nd based lasers operate at a fundamental of ~1um. 0.5um and 0.25um frequency multiplication is efficient and available as standard commercial products.

F₂ Excimer lasers at 157nm are the shortest wavelength conventional lasers. There is much work for the semi-conductor industry to make them more practical.

Power: Need ~10MW peak power.

Transverse mode: Need TEM₀₀. **Note: many high power lasers do NOT produce single transverse mode beams!**

It is possible to use a vacuum spatial filter on a high power laser beam, but the system is complex, and subject to damage.

Short Term Temporal Structure Requirements

Pulse must be uniform over measurement time scales.

Mode-locked lasers typically produce smooth temporal profiles in short (ps) pulses.

Q-switched nd:YAG lasers produce long (nanosecond) pulses with large amplitude variations on $>$ GHz time scales (limited by the bandwidth of the laser).

Injection seeded Q-switched lasers operate single frequency and have smooth temporal profiles.

Very broadband Q-switched lasers (Ti:Sapphire) have temporal variations on very fast time scales that are averaged by the electron beam.

Long Term Temporal Structure Issues

For most laser experiments the LASER is the expensive part, and the experiments are designed around the temporal structure of the laser. There is little incentive for laser companies to produce custom, complex time structure lasers.

Flash lamp pumped lasers: Operate at low repetition rates, high powers. High gain gives short Q-switched pulse lengths ($\sim 10\text{ns}$). Typical lasers operate at 10Hz. High frequency lasers (commercial) top out at about 100Hz - might push to 120Hz. High output powers $\sim 10\text{MW}$.

Repetition rate is limited by average thermal effects in the rod (thermal lensing). Increasing average power typically degrades transverse beam profile.

CW lamp pumped lasers: Operate at repetition rates determined by the excited state lifetime of the material (1-10KHz). Low gain, so output peak power is typically low ($< 100\text{KW}$)

Diode pumped lasers: Replacing CW lamp pumped lasers, with slightly better performance. Not yet commercial replacing high peak power lasers.

Laser Systems for NLC Linac Laser Wires

Beam pulse structure: 95 Bunches, 1.4nsec spacing, 120Hz.

Beam size: 0.9 x 7.5 Microns.

Laser Wavelength: 266nm (4 X YAG).

Use 60Hz Q-switched, Injection seeded YAG.

60Hz laser off pulses used for background subtraction

Simple, commercial device: Coherent Infinity: 25mJ, 2.5ns (10MW), at 266nm.

~\$120K.

Scan time, 30 points / scan: 1/5 second for single bunch, 20 seconds for full train.

Spot Parameters: $R1 = 5.6\mu\text{m}$, $\sigma = 0.34\mu\text{m}$.

Lens $F^\# = 2.3$ for nominal beam. Probably should be adjustable for larger $F^\#$, but smaller $F^\#$ will be difficult. Set range $F^\#=2-8$.

Lens aperture is .25cm (for $1\text{J}/\text{cm}^2$), at minimum $F^\#$. Need aperture of 1cm for full range.
Focus Distance = $\sim 2\text{cm}$.

Other Issues for Laser Wires

Reliability: Laser wires must be operated as diagnostics, not experiments.

Calibration: There must be a diagnostic to detect optical spot degradation.

Safety / Machine Protection: These are high power lasers. The safety systems may represent a non-trivial cost.