

# **Special Instrumentation for the 8-Pack Project**

Josef Frisch 2/20/2002

## Special Instrumentation: Overview

- Instrumentation which does not clearly fit into other categories
- Primarily used to diagnose problems, and calibrate other systems.
- NOT part of NLC

Note: Budget / Labor not yet approved

Acoustic Sensors: Used to Locate RF breakdowns

M+S cost ~35K

Photomultiplier tubes: Use to locate RF breakdowns

M+S cost ~12K

RF Component Temperature Measurements: General diagnostic

M+S cost ~7K (Conventional system - not discussed further)

Thermal RF Power Measurement: Calibrated high power RF power measurement

M+S cost ~11K

“General purpose” Lab instruments: Power meters, function generators, etc.

M+S cost - variable, \$25K to \$100K

# Acoustic Sensors

Function: Used to locate RF breakdowns. Provides ~few cm resolution.

Description: Pulse heating of RF structures generates acoustic signals which have been measured at frequencies from ~1 KHz to ~1MHz, limited by the detection equipment. Pulse heating and measurable acoustic output is produced by normal RF pulses, and increases by a factor of ~10 in amplitude for “breakdown” pulses.

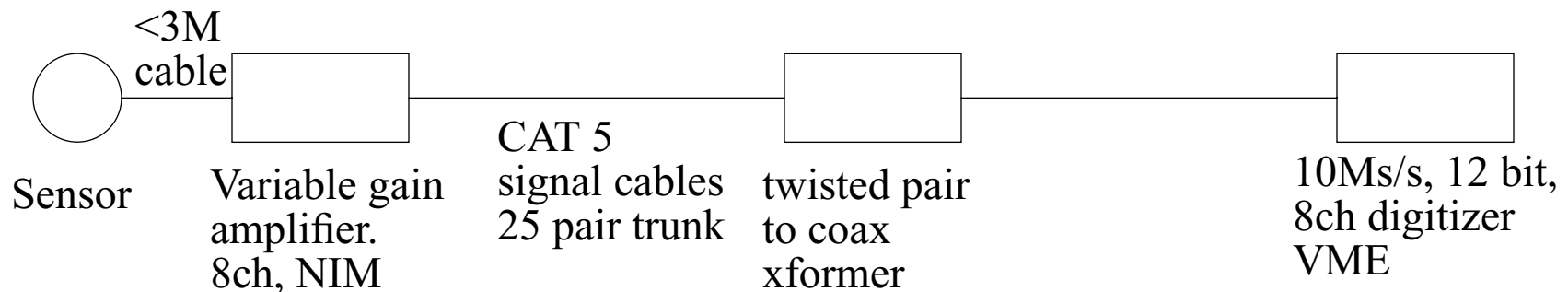

Hardware: Nearly identical to operating NLCTA system  
Testing new sensors (low cost commercial, SLAC constructed).

Software: Identical to operating NLCTA system  
Optionally can use SIS 100Ms/s digitizers in place of Joerger 10Ms/s units.

# PMTs

Function: Used to locate breakdowns, optionally for fast interlocking.

Description: Photomultiplier tubes (possibly with scintillators) are mounted near high power RF components. X-rays generated during RF breakdowns will be detected and their amplitude and timing measured. Optionally, a discriminated output can be used as a fast RF interlock.

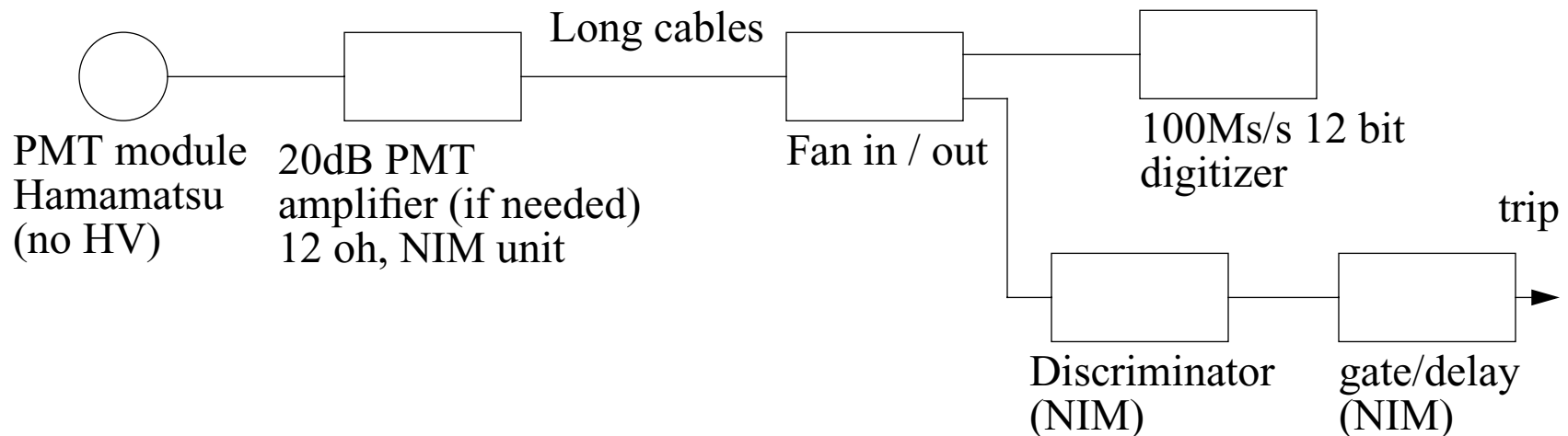

Hardware: Integrated PMT modules eliminates HV system. Transient digitizer same as for LLRF system. Fast interlock goes to LLRF system (if needed).

Software: Treated as LLRF channel in EPICS. Off line analysis done in Matlab.

# Thermal Power Measurement

Description: An accurate measurement of the thermal power removed by the water to the RF loads is made. This should provide a <5% absolute accuracy RF power measurement.

System Inputs: 38Gpm water, 54KW (120Hz) -> 5°C delta T.

Want to measure 60Hz. 50% power = 1.25°C delta T to 2%, need 0.025°C  
Need water flow to 2% (0.75Gpm).

Temperature measurement: Differential thermocouple, need 1 microvolt stability.

Can use HP3458 voltmeter (existing) with GPIB

Alternately build front end from AD8628 pre-amp (<.005uV/C drift).

Flow Measurement: Need 2% accuracy reading

Turbine flow meters provide ~1% absolute accuracy (e.g. Omega FL8305AB).

Substitution Heater: Independent calibration.

Need ~30KW water heater (commercial). Use 480V line, measure Vrms and Irms.

Pulse Profile: Need RF pulse shape measurement linear to 1%. (LLRF system OK?)

# General Purpose Instruments

**A variety of general purpose instruments are require, and not costed elsewhere.**

Peak Power Meter: HP8991. Obsolete, but no substitute available for fast pulse measurements. Invaluable in NLCTA. \$14K (used marked).

Good General Purpose Scope: Various available. ~15K.

X-band Synthesizer: Various. Need to check which units are not allocated. Need on for general measurements. ~\$35K

Miscellaneous RF hardware: Attenuator, mixers, amplifiers, diodes, etc. ~10K (2002)

Arbitrary waveform generator: For special purpose testing of RF modulation schemes. Best to borrow, only needed occasionally. ~\$20-60K