

# **The NLC RF Phase and Timing Distribution System**

**May 17, 2000**

Josef Frisch, David Brown, Eugene Cisneros

# Subsystems

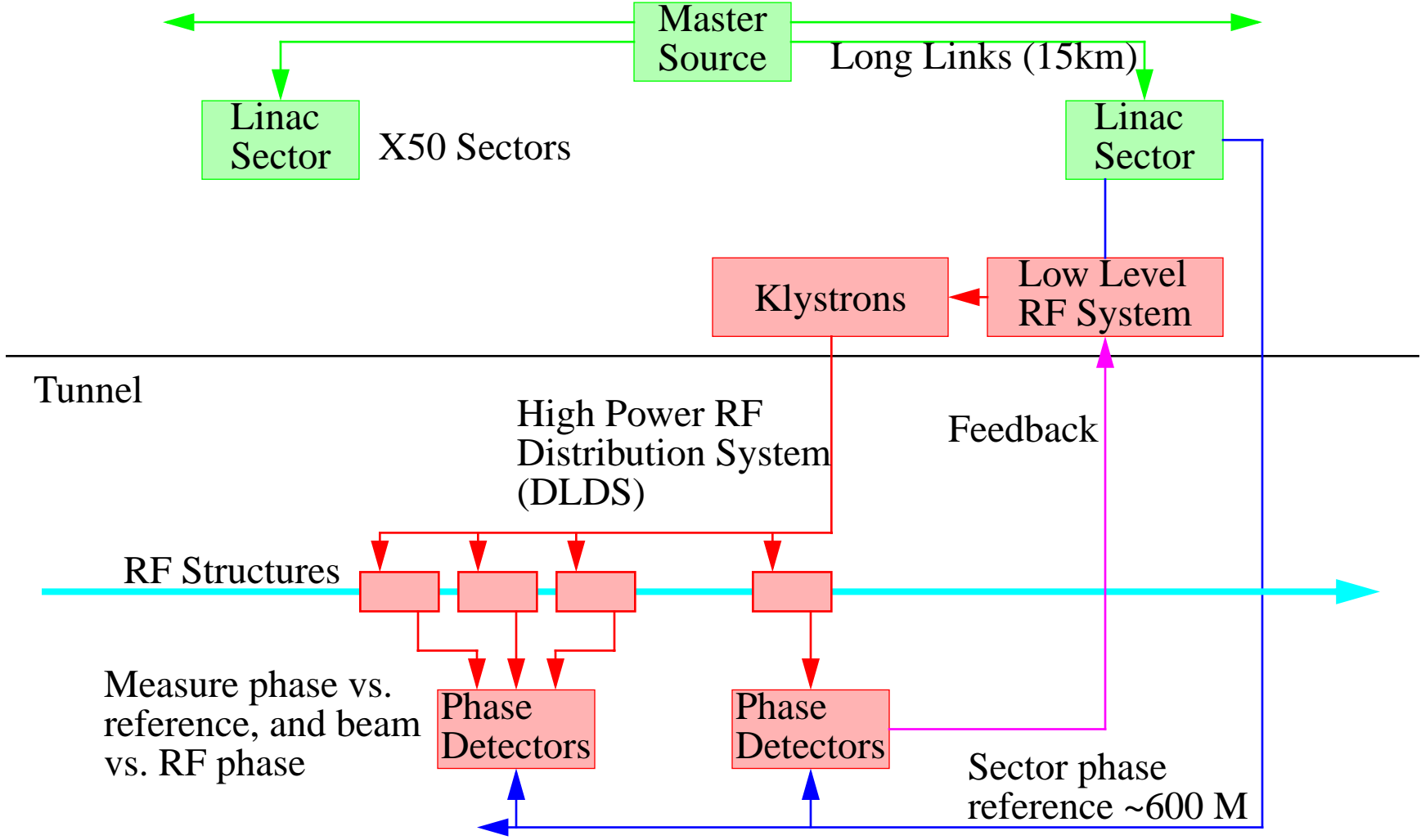

## Phase distribution system: Sub-systems

**Long Links:** Need  $<1^\circ$  X-band stability over 15 Kilometers for timescales less than beam phase measurement time. Need long term stability  $< 20^\circ$  X-band.

Addition requirements for reliability, Machine protection (no single point failure can be allowed to drive the beam into the wall).

System uses phase length stabilized fibers in a point to point distribution system.

**Sector Phase Reference:** Need  $< 1^\circ$  X-band over 600 Meters. System must operate in the tunnel radiation environment ( $\sim$ few Rad/hour).

System uses temperature controlled coax, with phase measurement / compensation.

**Beam phase measurement:** Need to measure beam phase vs. Reference phase to  $1^\circ$  X-band. Need to measure the Beam vs. Klystron RF phase to  $1^\circ$  X-band.

System uses beam induced fields, measured relative to the klystron RF.

## Long links - Operating Principle

**Fiber vs. Coax:** Both have similar  $\sim 10^{-5}/^{\circ}\text{C}$  temperature coefficients of phase length.

Note that fiber phase length change is dominated by refractive index change with temperature, not physical length change.

Open loop system would require  $.005^{\circ}\text{C}$  temperature stability for  $20^{\circ}$  X-band stability.

### Need Feedback

Single mode fiber has much higher length X bandwidth product: Use fiber at 1550nm wavelength to minimize optical loss.

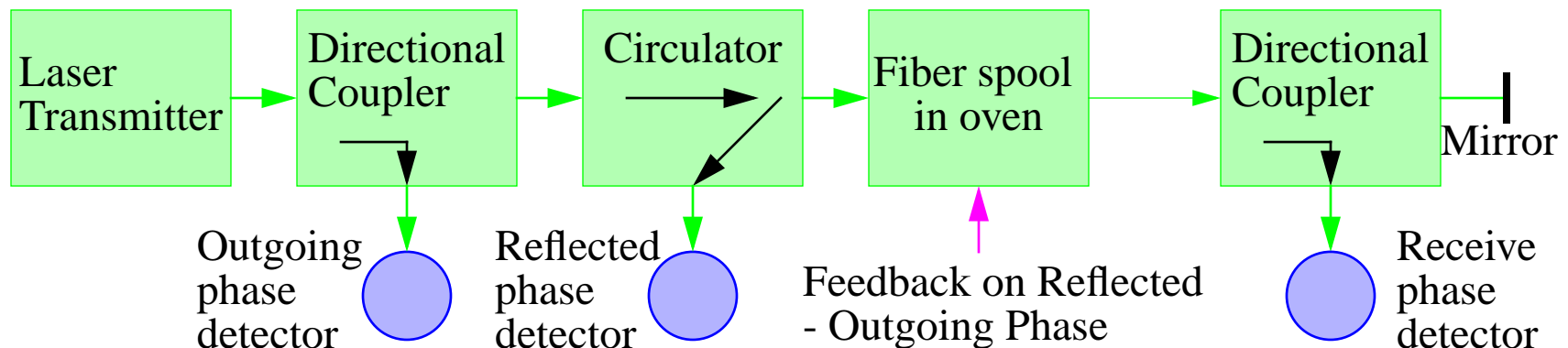

System assumes that changes in outgoing and return phase length are identical

## Long Links - Noise

**Performance Requirements:** We assume that the long links are responsible for the majority of the allowed long term drift ( $\sim 20^\circ$  X-band), and 1/3 of the high frequency noise (allow  $0.3^\circ$  X-band from the long links).

**Transmission Frequency:** Higher frequency reduces noise, Ideally as  $f^{1/2}$ .

At frequencies above a few GHz, the spectral sidebands from the intensity modulation can destroy the correlation between the forward and reflected phase shifts.

At  $\sim 500$ MHz there is a cost break point. Present system operates at **357MHz** (1/32 of the X-band RF). **Final system frequency will depend on technology.**

In order to measure  $0.3^\circ$  X-band at 357MHz we need  $.01^\circ$  phase measurement. (tough, but not impossible).

**Master Source Phase Noise:** Need an integrated phase noise of  $\sim 76$  dBc above  $\sim 10$ KHz (fiber length). **This specification is met by good quality frequency synthesizers or VCXOs.**

## Long Links - Noise (continued)

Noise from fiber system is fairly flat over frequency. Need to use a VCXO PLL at the receiver end to bandwidth limit the signal and reduce overall system noise.

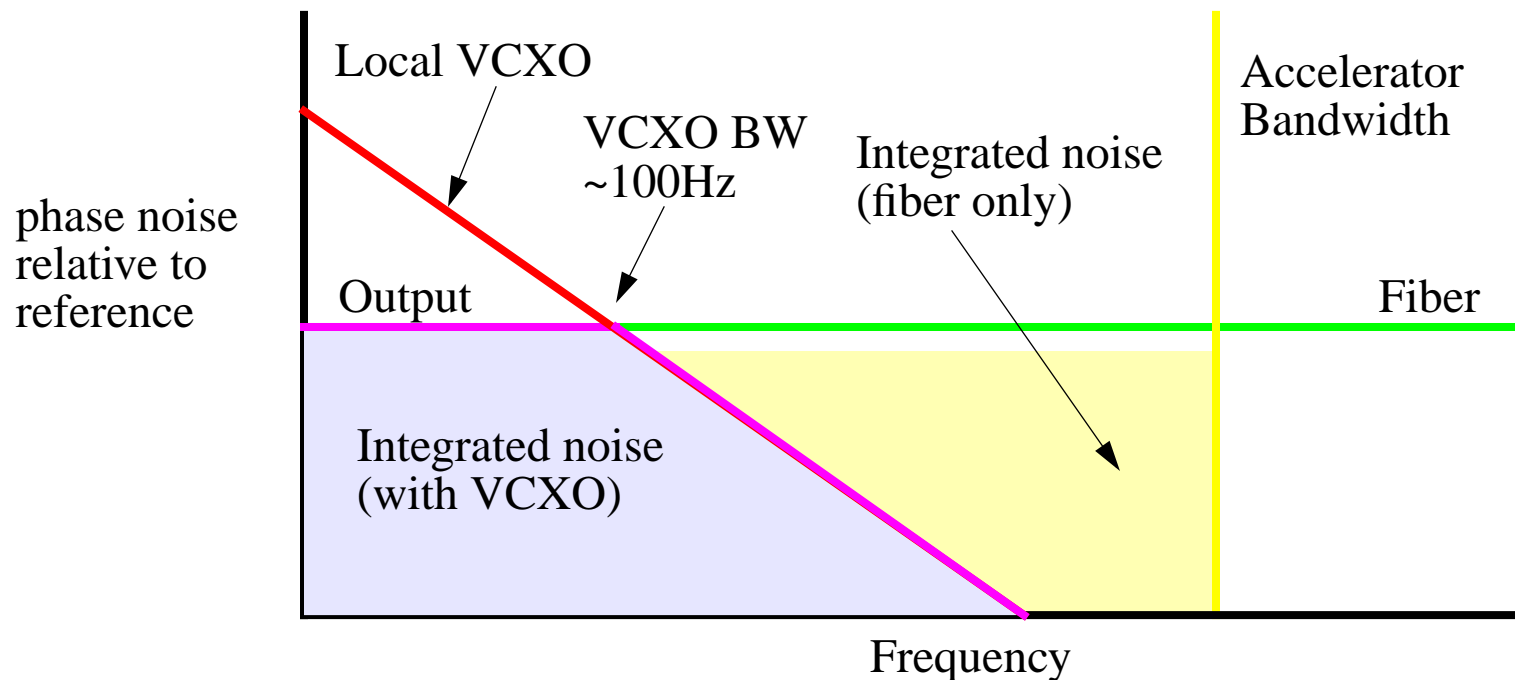

**PLL VCXO noise requirement:** If we assume a VCXO noise power which varies as  $1/f^3$  (typical), then we need a noise at 100Hz of  $<-93\text{dBc/Hz}$ . This requirement is easily met by good VCXOs. Low noise VCXOs can operate with a bandwidth as low as 30Hz.

## Long Links - Noise (continued)

**Receiver:** Standard telecom receivers in this bandwidth range have  $\sim 6\text{pW/Hz}^{1/2}$  noise. If we assume a 100Hz receiver bandwidth (controlled by the PLL), we can operate at received optical powers as low as  $\sim 1\mu\text{W}$ . (we expect to operate at  $\sim 10\mu\text{W}$  on the lowest power receiver.)

**Shot Noise:** The minimum optical power to obtain the required shot noise is on the order of nanowatts (not an issue).

**Transmitter:** Need short term wavelength stability  $< 5 \times 10^{-4}$  nm, linewidth  $< \sim 0.25\text{nm}$ . Maximum transmitting power is  $\sim 10\text{mw}$ , limited by nonlinear frequency conversion (Brillouin scattering).

**Transmitter noise requirement:** Assuming a 100Hz receiver bandwidth, we need a relative intensity noise of  $< -95$  dBc/Hz RIN. Good DFB diode have RIN  $< -130$  dBc/Hz.

DFB Laser diodes meet our requirements.

We are Also considering a wavelength tunable fiber laser (described later).

## Other Sources of Errors

**VSWR:** Reflections are the bugaboo of most RF length feedback schemes.

We need optical power reflectivities of  $< -75\text{dB}$  (assuming coherent reflections),  $< -37\text{dB}$  for incoherent reflections.

Typical components (with FC/APC connectors) have  $< -55\text{dB}$  return loss. This is sufficient for long runs, but may be an issue for short runs where we can have coherent reflections.

Typical DFB lasers have a linewidth of a few MHz, giving a coherence length of hundreds of meters.

Fortunately, in our system the DFB laser is operated pulsed, and its wavelength sweeps during the pulse. This averages out any coherent effects.

**Nonlinearities - Mixers:** Tests on mixers indicate that operation at RF levels less than minus 20dBm reduces nonlinear amplitude to phase conversion to an acceptable level.

**Nonlinearities - Other:** The detectors, amplifiers, etc. can all be a source of amplitude to phase conversion. We are still studying these issues - but no major problems have been found.

# Test System

**Test Fiber Length:** 15 Kilometers in temperature controlled oven.

**Frequency:** 357MHz

**Transmitter:** DFB laser diode, 1mw at 1550nm

## **Phase Detection:**

Pulse diode on for  $\sim 50\mu\text{s}$  ( $<$  fiber length)

Combine detected signals. Three detector signals now “time multiplexed”.

Mix received signals down to 25KHz.

Digitize 25KHz IF at 200KHz, 16 bits (12 effective bits).

Fit sine and cosine (digital phase detection).

Data Acquisition cycle of 10Hz. Approximately 50% of time used for acquisition.

## **Length Adjust:**

Use external oven with 6 Kilometers of fiber, range  $\sim 60^{\circ}$  C.

Oven uses a constant TEC cooler with a fan blowing air over a hot wire grid.

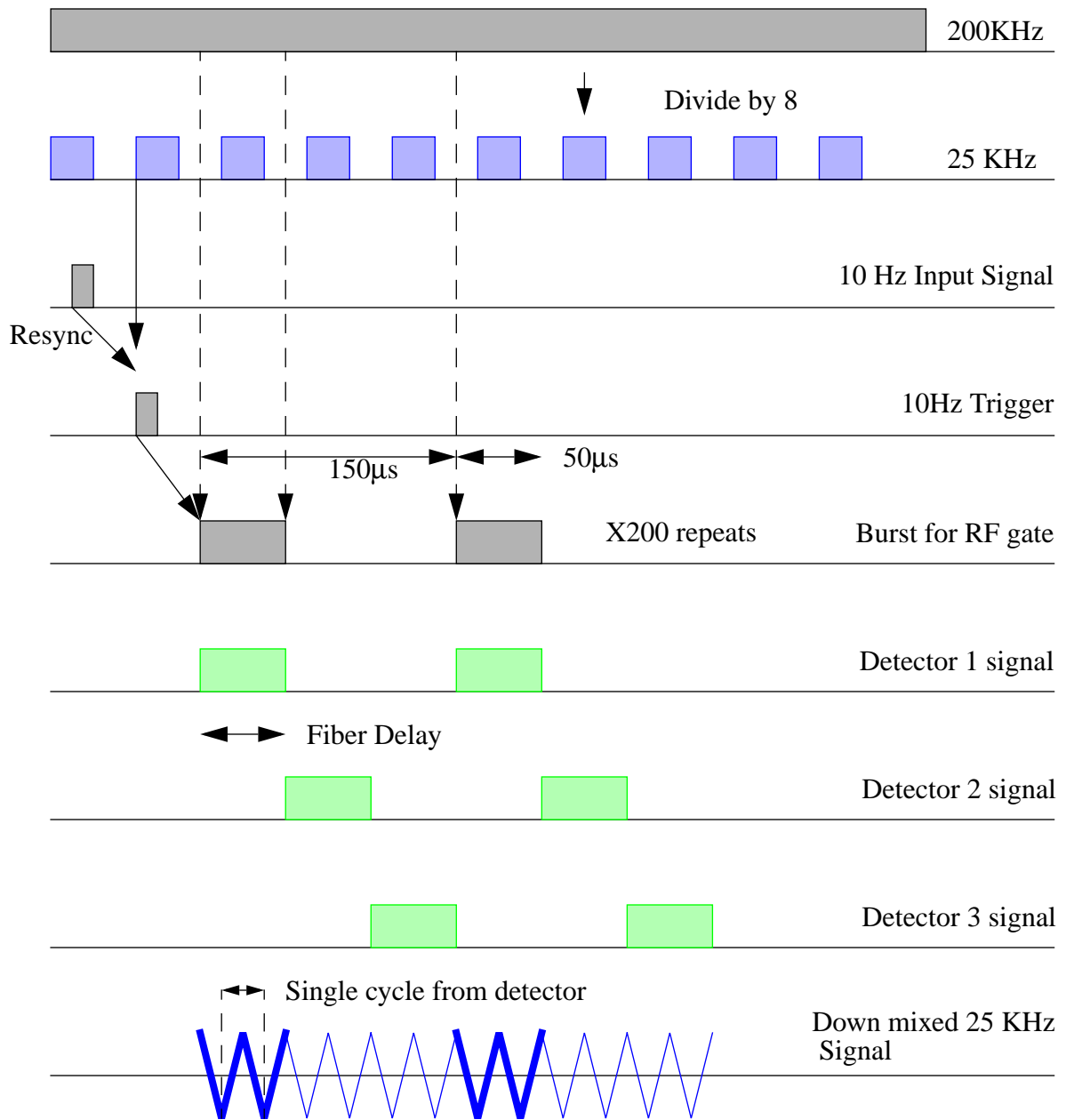

Entire cycle repeats at 10Hz. Note that burst spacing is determined by fiber length.

# Test System - Block Diagram

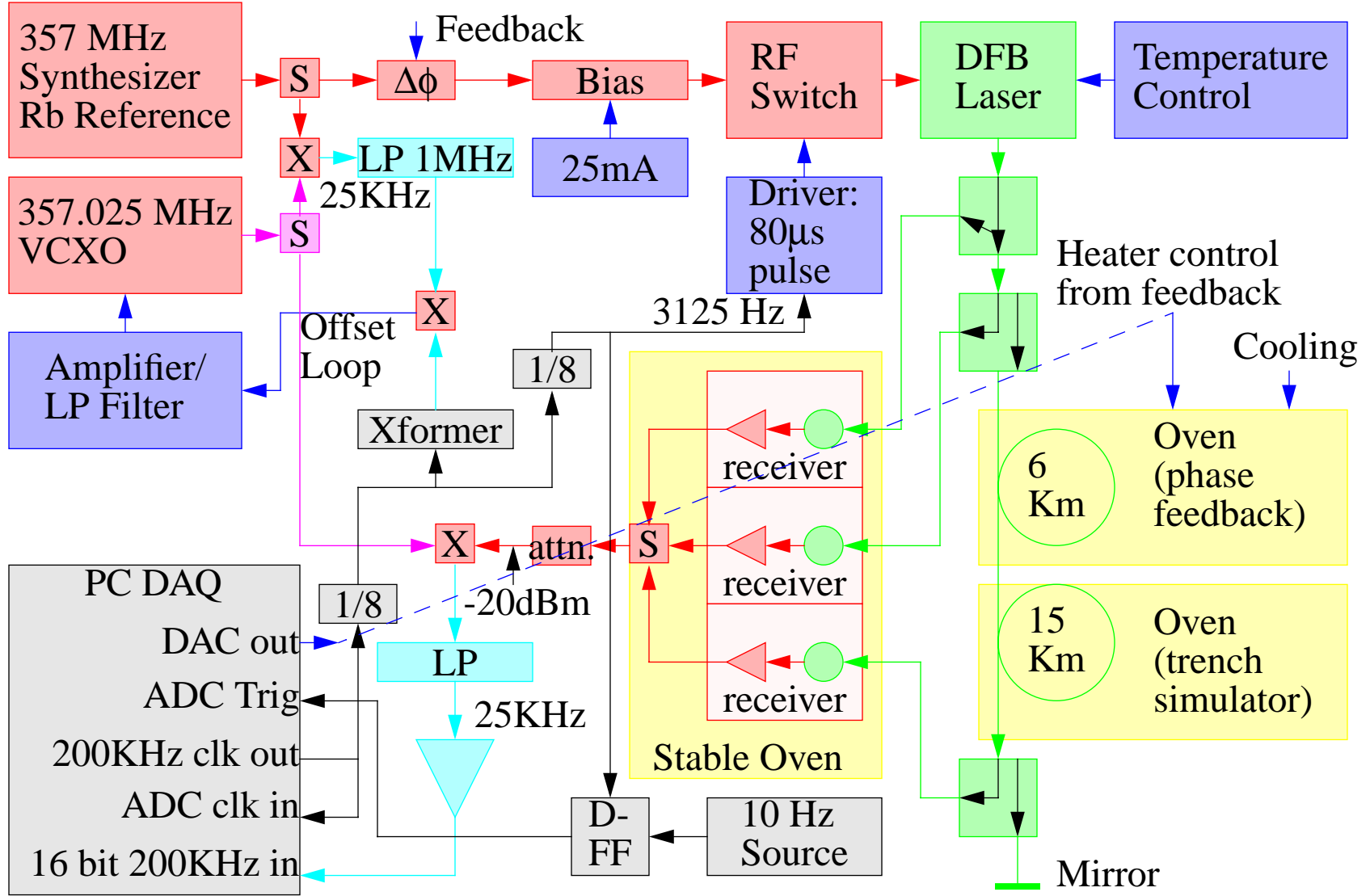

## Test System - Electronics performance (no fibers)

For this test, the output of the RF switch was attenuated and fed into the mixer. Noise (measured at 10 Hz) was  $0.11^\circ$  X-band (meets our spec).

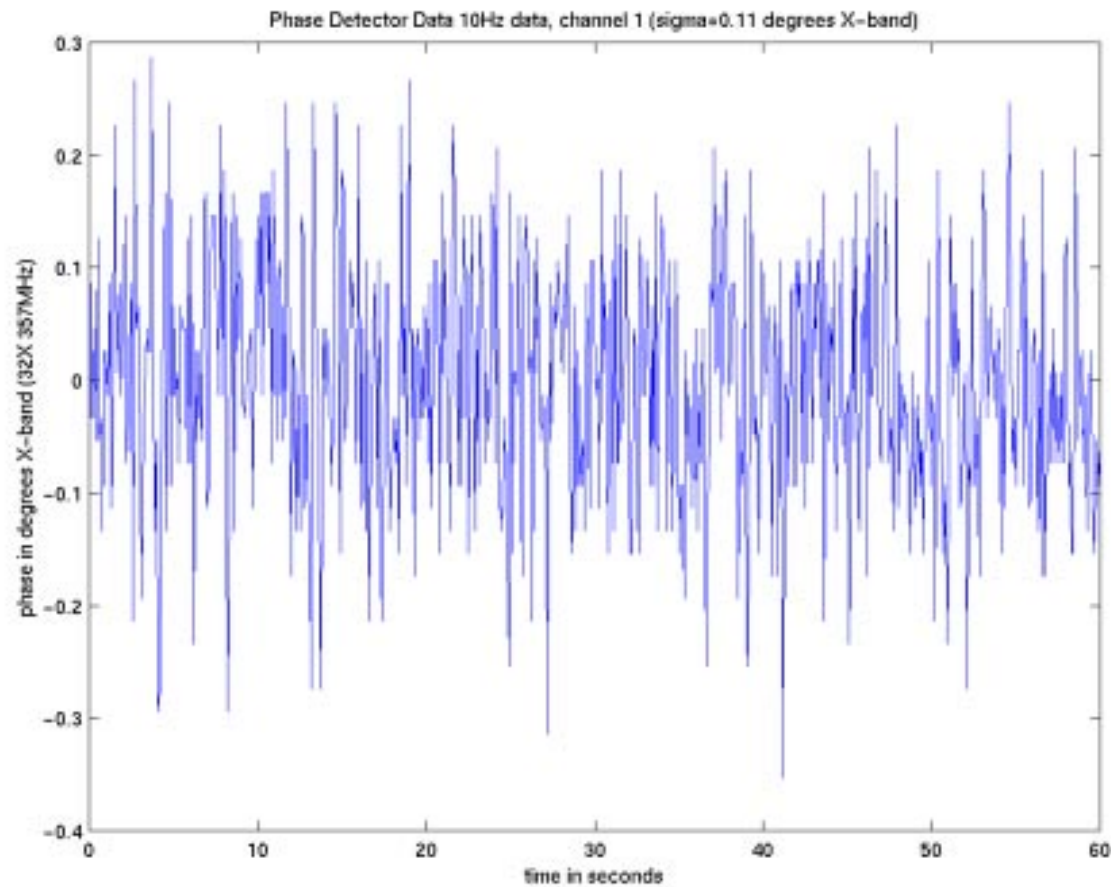

## Test system performance - open loop

The temperature coefficient phase for fused silica fiber results from the expansion coefficient  $5 \times 10^{-7}/^{\circ}\text{C}$  (small), and the index change  $\sim 10^{-5}/^{\circ}\text{C}$  (dominates). For a 15Km fiber, we expect a phase sensitivity of  $2800^{\circ}\text{X-band}/^{\circ}\text{C}$ . We observe  $\sim 2200^{\circ}\text{X-band}/^{\circ}\text{C}$ .

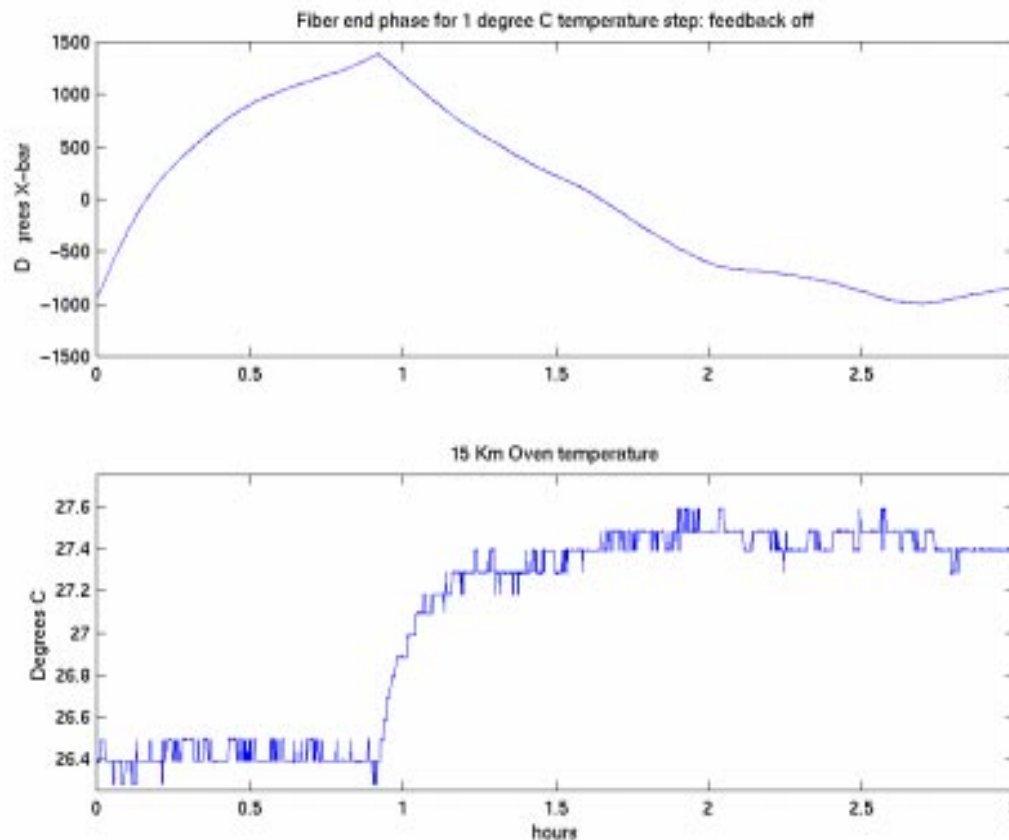

## Test System Performance - Closed Loop

With the feedback on, the reflected phase signal shows no variation (other than broadband noise). The Feedback oven temperature is controlled. Output shows  $<0.2^\circ\text{X-band}/^\circ\text{C}$ . (Factor of 20,000 improvement). Noise is  $0.8^\circ\text{X-band RMS}$  (outside of steps).

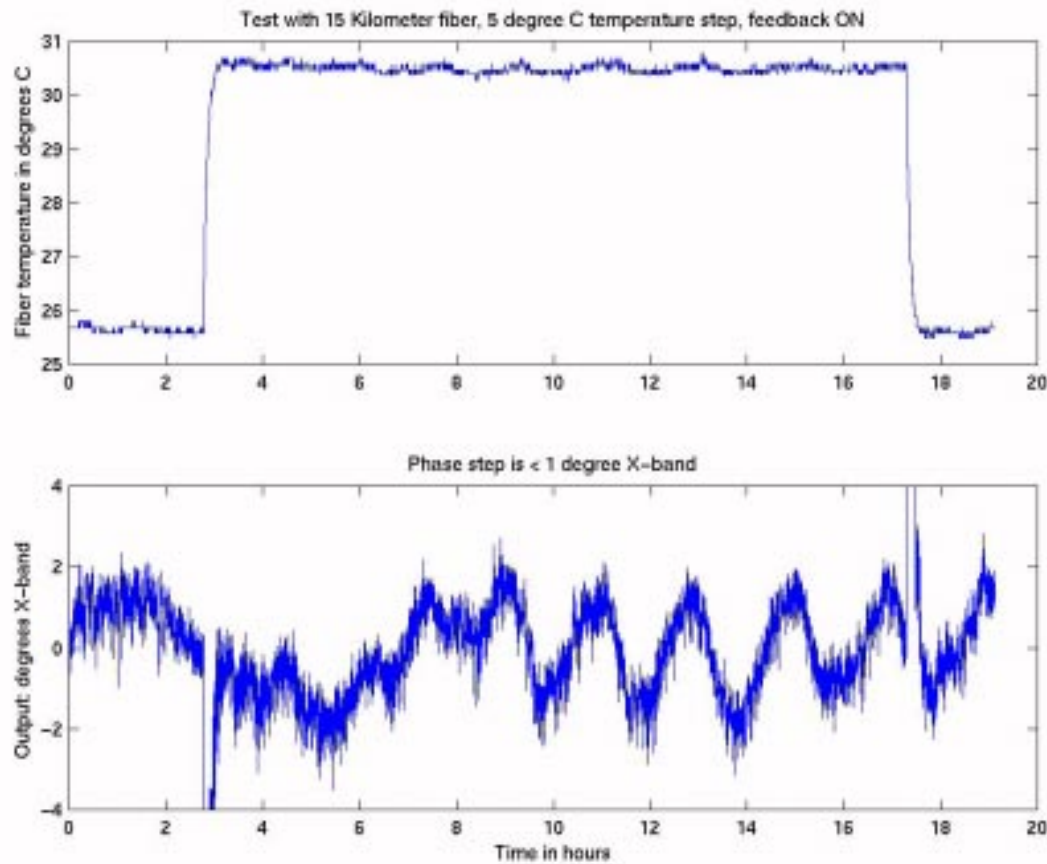

## Long Fiber Link System: Present Status

Parameter	NLC System	Test System - measured
Transmission distance	1 to 15 Kilometers	15 Kilometers
Fiber temperature range	+/- 5°C*	+5°C (+/- 10°C expected)
Long term phase stability	+/- 20° X-band	+/- 3° X-band (3 day test)
Phase temperature coefficient	< 4° X-band / °C*	<3° X-band / °C
Phase Noise	<0.1° X-band, 10Hz BW	0.8° X-band, 10 Hz BW 0.4° Short term noise

\*Based on SLAC summer / winter temperatures and 1 Meter burial depth

### Phase Noise Improvement Plan:

Install low noise VCXOs. Synthesizer phase noise may be the limiting noise.

Install phase feed forward. High frequency (< 1 minute) noise is only 0.2° X-band. Can fix slower residual noise with feed forward.

## Long Link Fiber System - Wavelength Tunable Laser

An alternate length control method is to use a wavelength tunable laser which couples with the fiber dispersion to change the effective fiber length. **Eliminate Ovens**

Standard tunable lasers either have excessive step sizes, or use moving mechanical components which are unsuitable for continuous feedback operation.

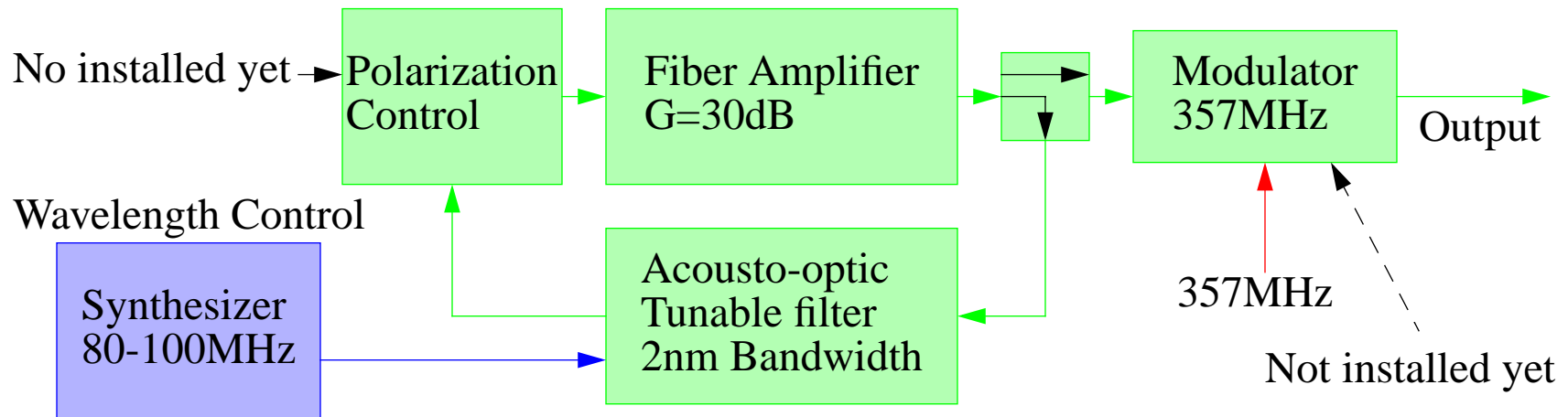

Parameter	Requirement	Demonstrated
Tuning Range	40nm	50nm
Wavelength step size	<0.5pm	<1pm (measurement limit)
Noise	-95dBc/Hz RIN	Not measured

Development on hold while ATOF is repaired

## Sector Phase Reference

This system distributes the phase from the long fiber links throughout a ~600M sector. The stability and noise requirements are similar to those for the long links:  $\sim 0.3^\circ$  X-band.

**Technical issues:** (why is this hard?)

System has many pick-offs ( $\sim 100$ ), point to point links are not practical.

Some signals needed in the accelerator tunnel: radiation environment ( $\sim 1$ Rad/hour), fibers not suitable.

Need stability  $0.3^\circ$  X-band / 600M. =  $3 \times 10^{-7}$ .

### Planned Solution

Can we use temperature stabilized lines?

Temperature coefficient of copper is  $\sim 10^{-5}/^\circ\text{C}$ . Would need  $.03^\circ\text{C}$  stability (very hard).

Instead use good temperature stability  $0.3^\circ\text{C}$  (SLAC accelerator water meets this spec), and Feed Forward.

# Sector Phase Reference Feedforward Scheme

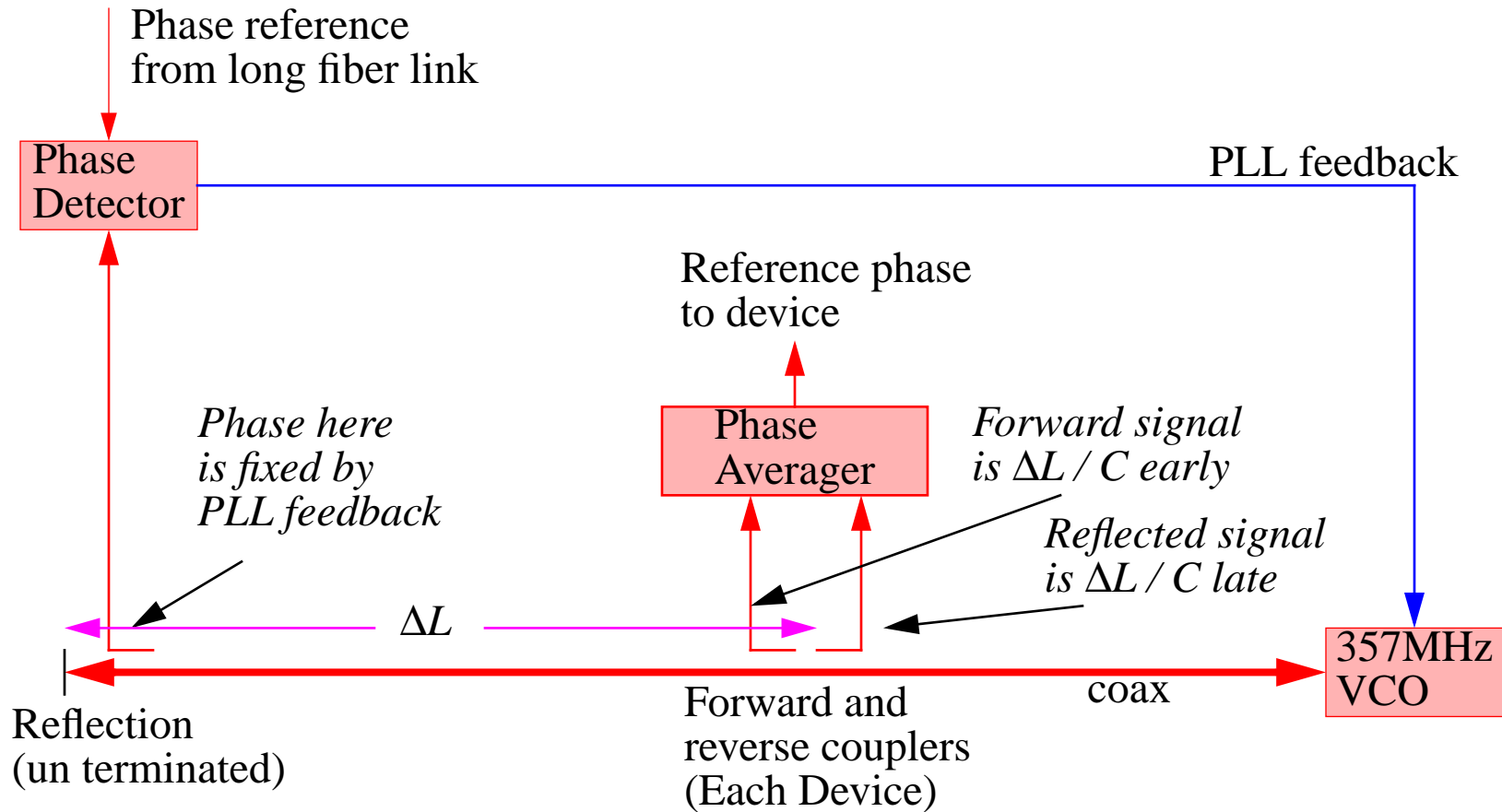

Ideally system corrects exactly for length changes for all devices.

**VSWR will reduce system accuracy - not yet calculated or tested.**

Summer student will work on a demonstration system.

## Sector Phase Reference: Phase Averager

**Phase changes are small:**  $\sim 0.1^\circ$  357 MHz ( $3^\circ$  X-band) if we have good temperature stability. **Can use linear system**

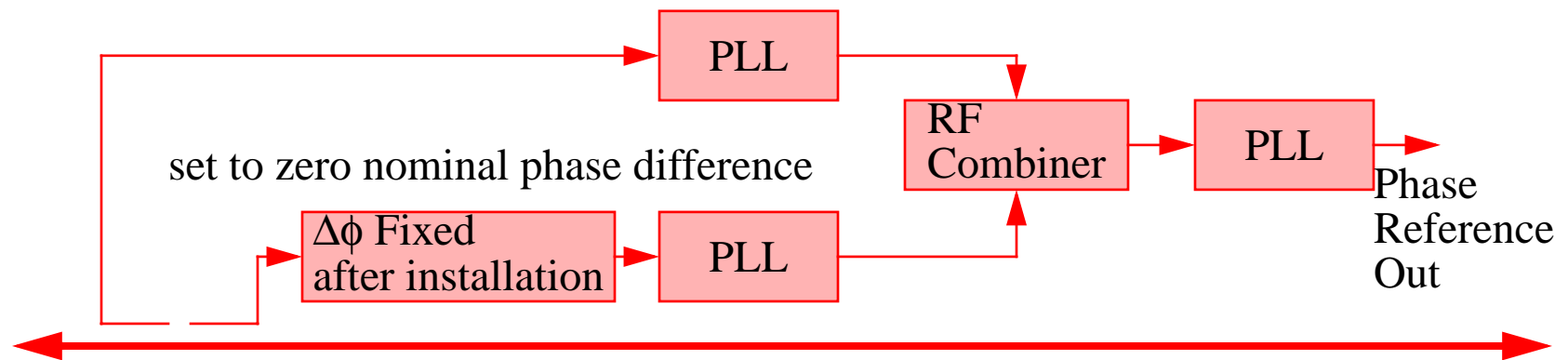

We will construct a prototype to test the performance of this scheme.

# Beam Phase Measurement

The beam phase can be measured relative to the klystron RF by looking at the beam induce fields in the accelerator structures.

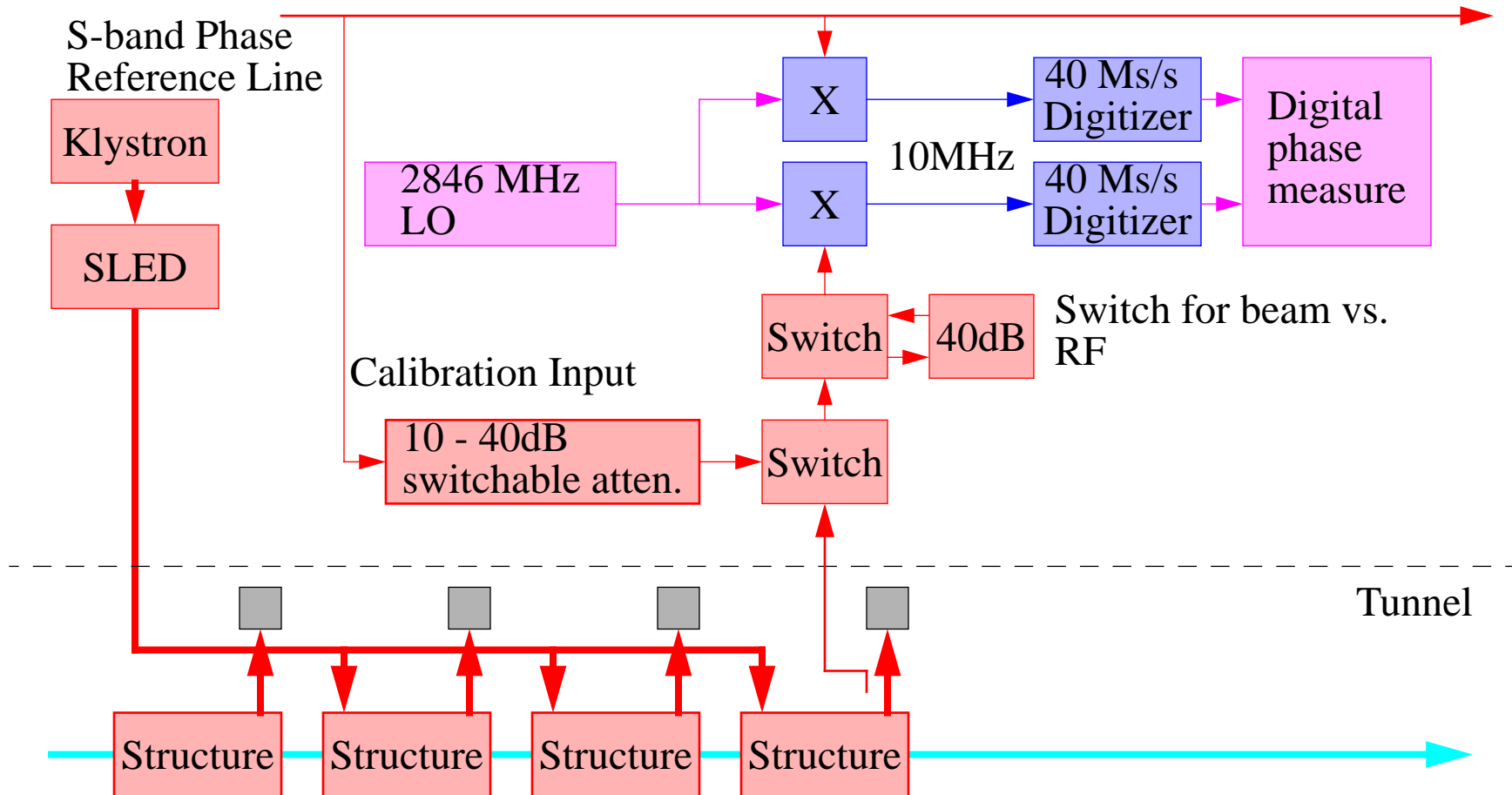

# Beam Phase Measurement: Results of Initial Tests

System was used to alternately measure the beam induced fields with the RF off, and the accelerating fields with the RF on.

Initial tests done at S-band (2856MHz) on the SLC linac.

Measurement noise (single pulse)	0.3° S-band RMS (calibration channel)
Measurement linearity	<0.3° S-band for 20dB signal variation
Measured drift of SLAC beam vs. RF	+/- 2° S-band over 10 Hours.

The RF signal level on the mixers was limited to -15dBm to limit nonlinear amplitude to phase conversion. Improved mixers should allow ~10dB improvement in noise. (~-.1° phase measurement on a single pulse).

Paul Corredoura has a scheme with signal averaging where the beam phase is detected in the presence of the accelerating fields. System to be tested in the next few weeks.

# Phase and Timing Distribution Work in Progress

**Self tuning PID feedback loop:** being debugged.

**Phase shifter feed forward:** Need to make narrow range (1° 357MHz) phase shifter. Software written (but not debugged).

**Low noise VCXO lock:** VCXOs on order, due June 8. Note that this will also be a test of the pulsed PLL

**Tunnel phase reference line test :** summer student to start in mid June.

**Beam phase measurement:** New system installed in sector 15, Finishing database changes and testing in next few weeks.

**Tunable fiber laser:** waiting for repaired part. (Now low priority since oven works).

**Other demonstration items:** Frequency Multiplier, Fiducial Transmission,

**Next generation tester:** Compact oven. Surface mount components. local micro??