

NLC - The Next Linear Collider Project



**4/8-Pack Low Level RF
Cost Estimates for the NLC 4-Pack
LLRF Monitor Hardware**

Andrew Young



Specifications

*Next Linear
Collider*

4-Pack:4 Klystrons to be monitored.

- Signal counts:
 - 4-Pack will have ~37 monitor points
 - 8-Pack will have ~100 monitor points
- Waveform Diagnostics (100MS/s) on select group of signals to measure breakdown,
- Monitor ports for Spectrum Analyzers,
- Single Pulse diagnostics using “Gated ADC”,
- Peak Detected signals sampled at 100MS/s.



NLC LLRF

Next Linear
Collider

RF Generator Block Diagram Digital Option

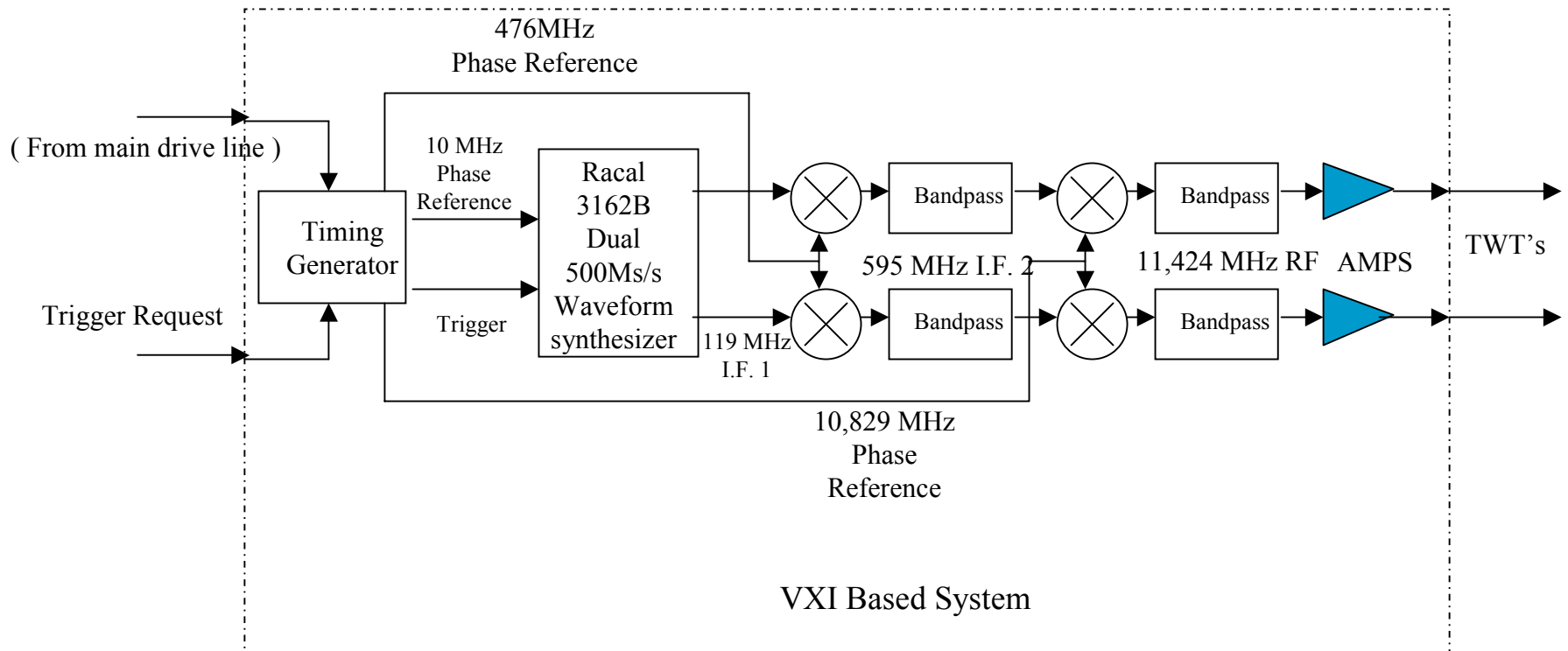



Baseband Vector Modulation Analog Option

*Next Linear
Collider*

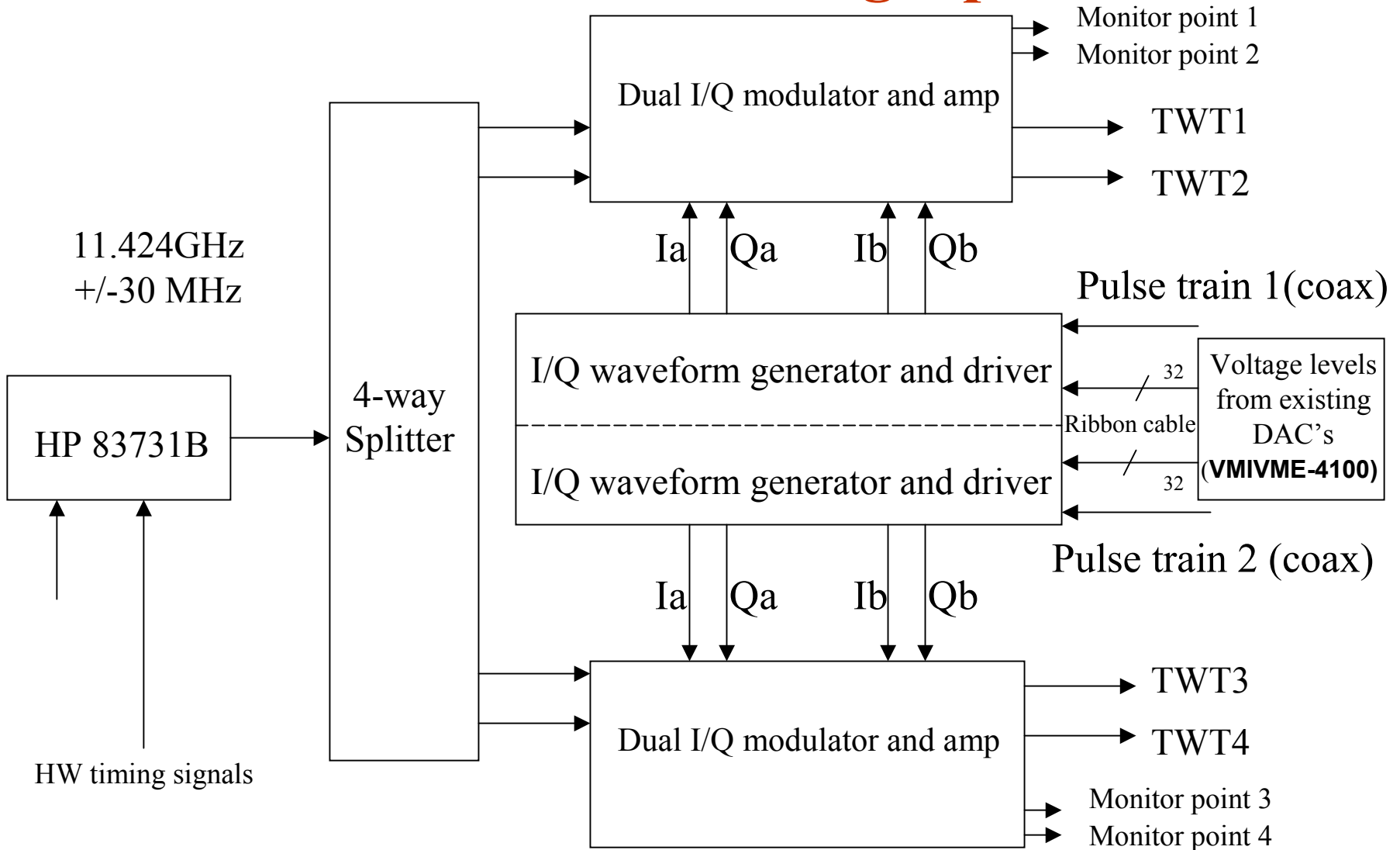



NLC

I/Q waveform generator and driver

Next Linear Collider

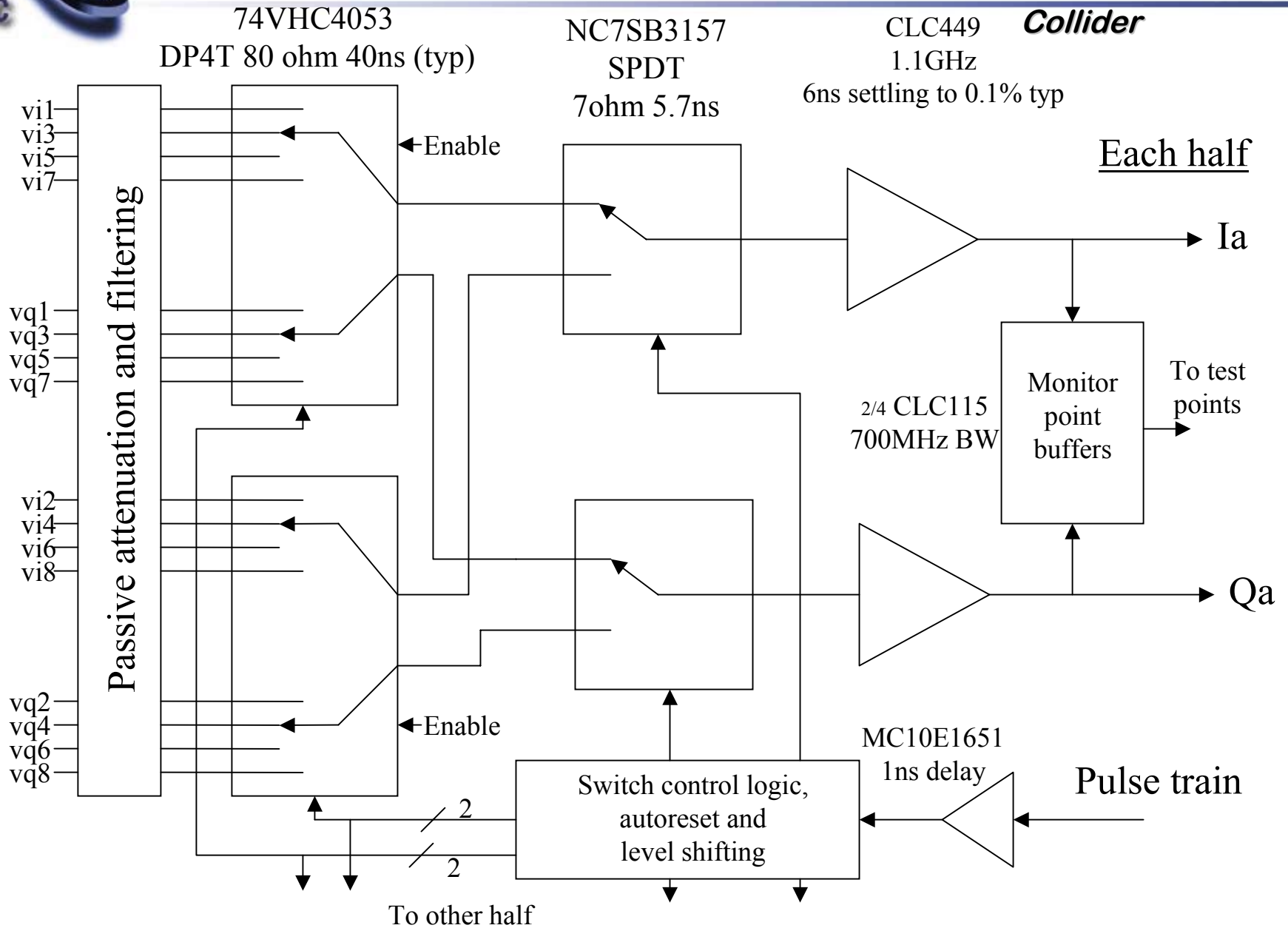



RF Monitor Block Diagram Rev2

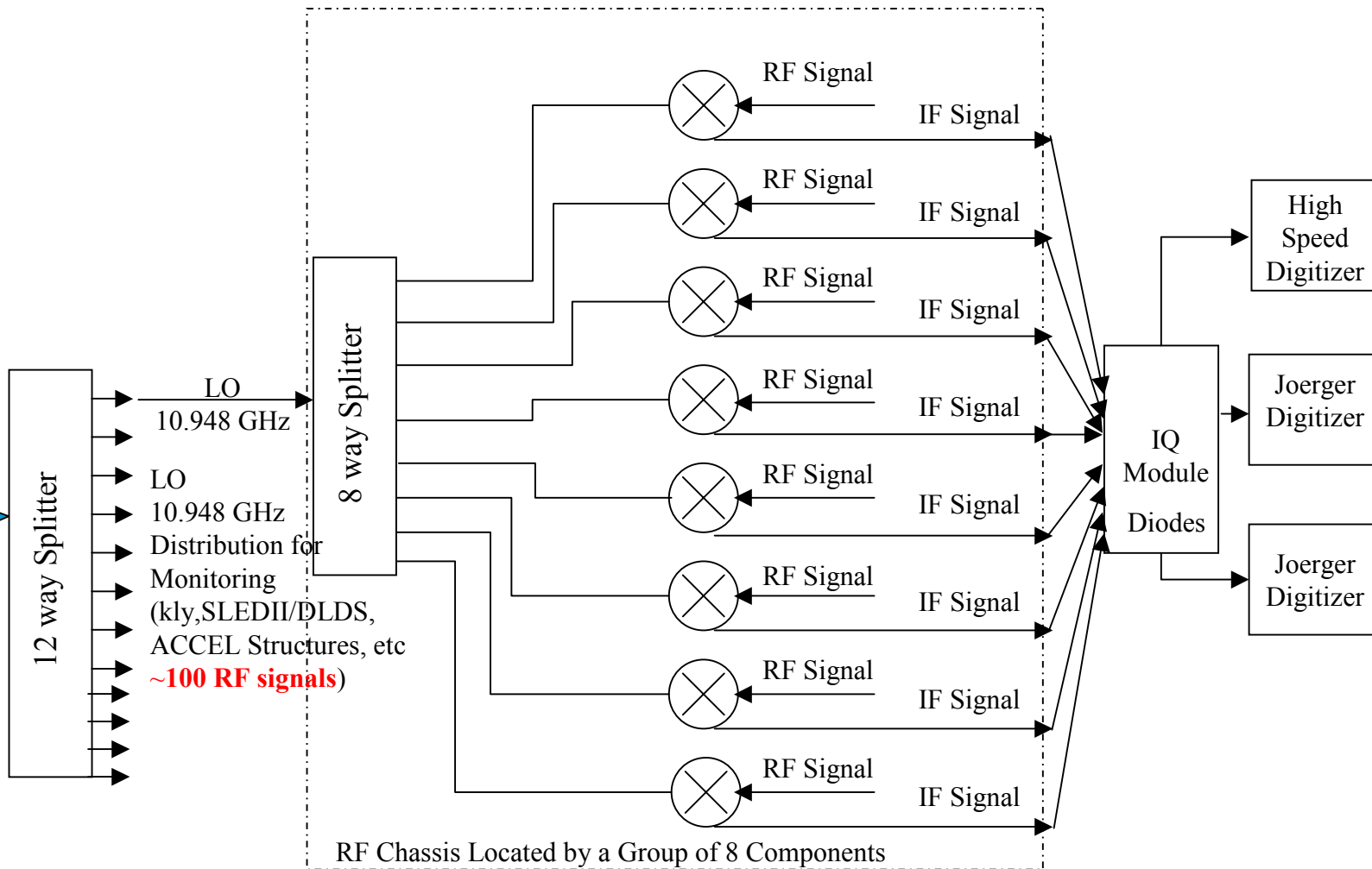

4-Pack RF Monitor Block Diagram

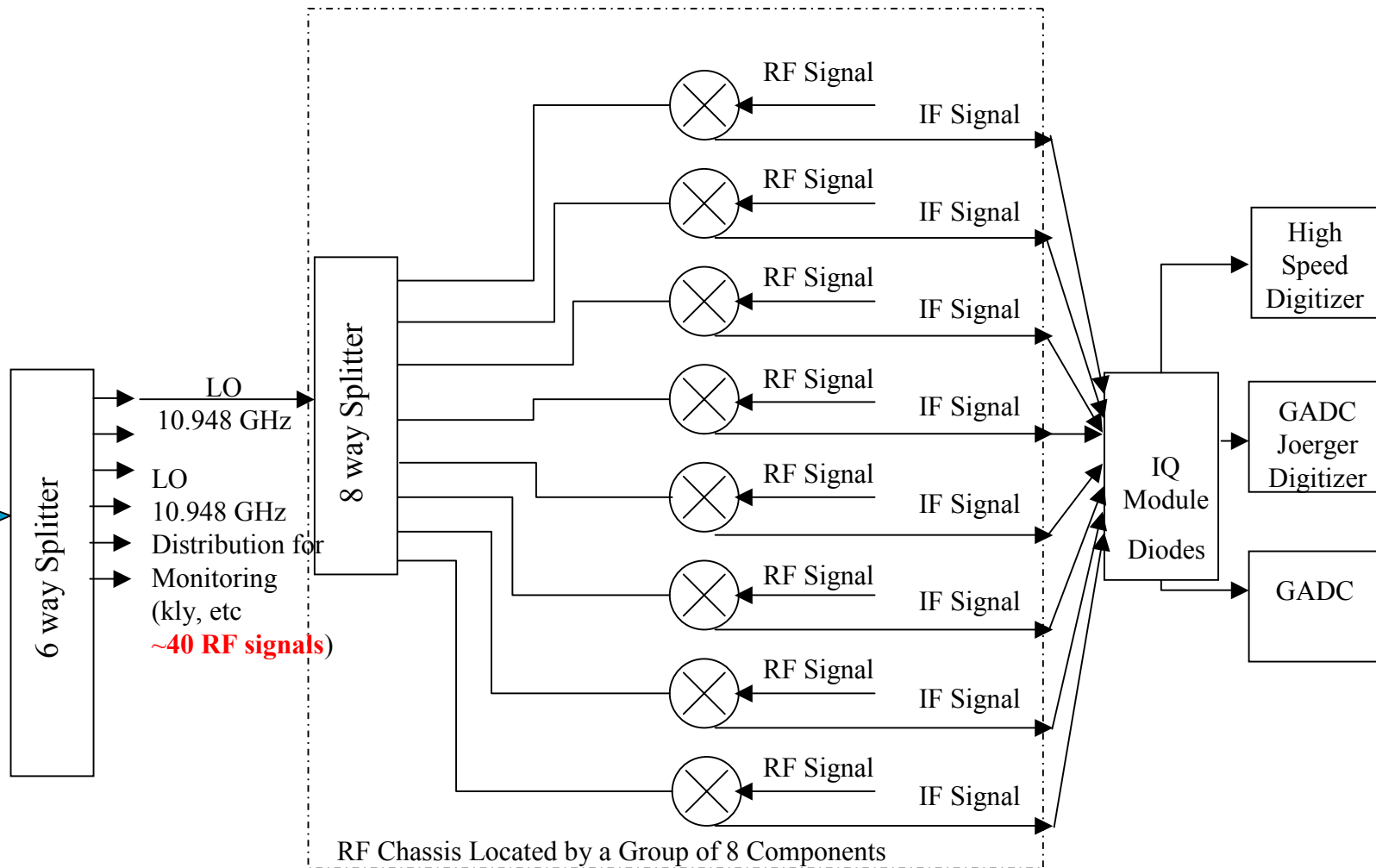



NLC

NLC LLRF

Next Linear Collider

IQ Module Block Diagram

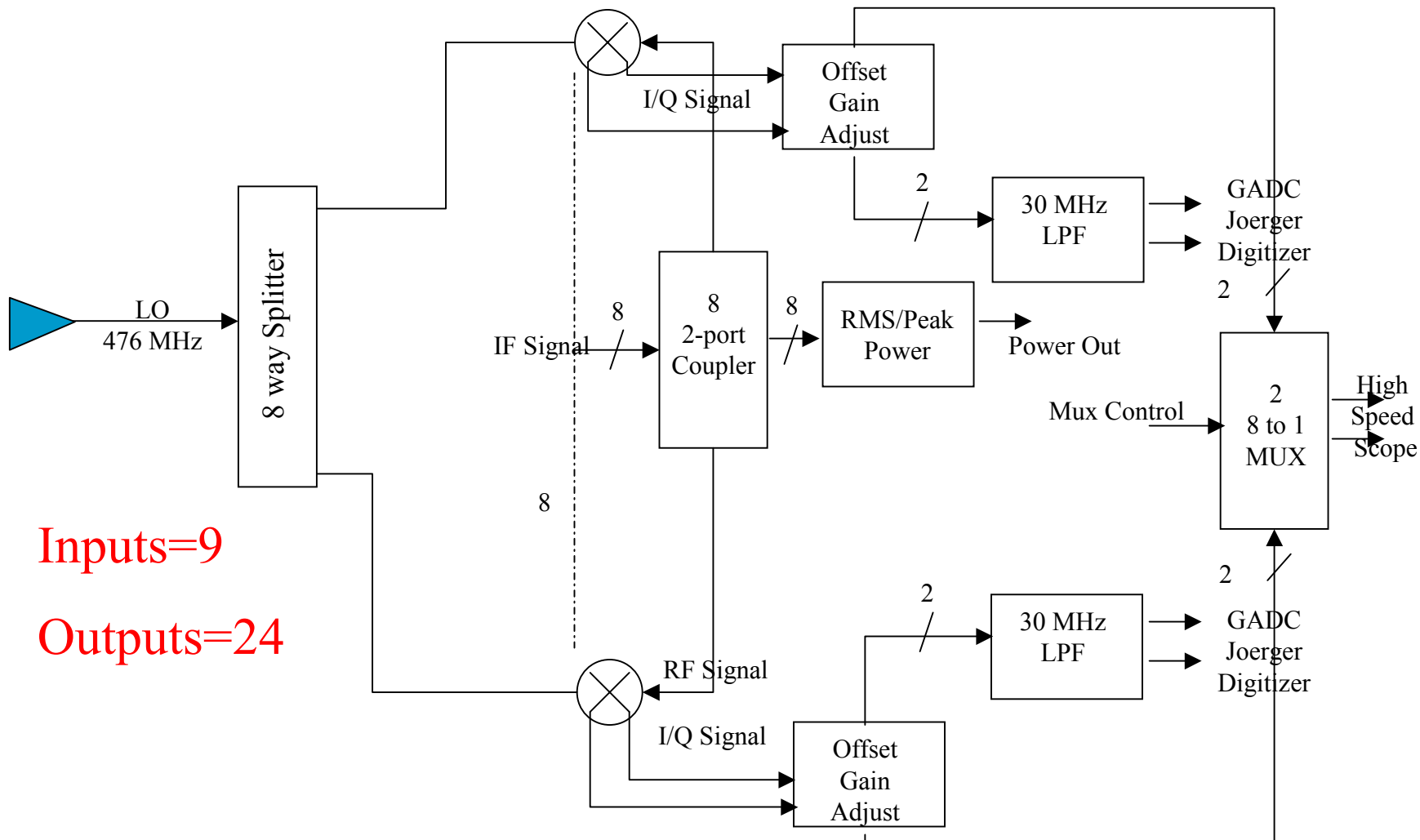



NLC LLRF Timing System

Next Linear Collider

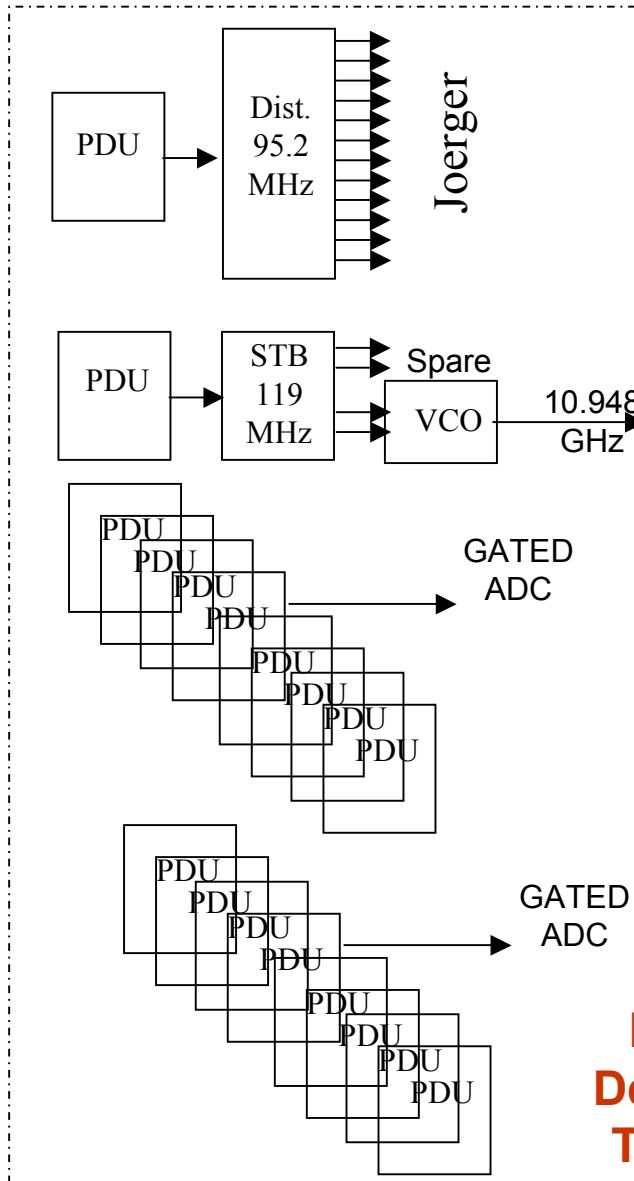

**LLRF
Detector
Timing**

**2 STB's
18 Ch. PDU's**



RF Monitor VME Crate #1 Layout

CPU	IF PLL	RF PLL	Joerger	Joerger	Joerger	IQA	IQA	IQA	IQA	IQA	MUX	MUX	Joerger	Joerger	GADC	GADC
-----	--------	--------	---------	---------	---------	-----	-----	-----	-----	-----	-----	-----	---------	---------	------	------

IQA Front Panel

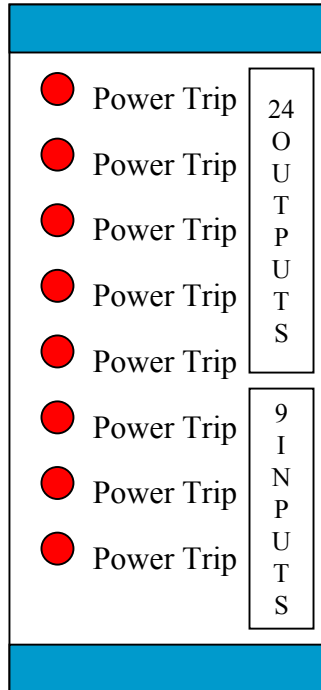



4-Pack NLC LLRF RF Generator Costs (analog additional)

*Next Linear
Collider*

- Hardware
 - Splitters \$1.6K
 - IQ Mixers \$1.6K
 - Amplifiers 20dbm X-band \$2.5K
 - Couplers \$2K
 - VME Crate \$5K
 - VME CPU \$5K
 - Filters \$1.5K
 - HP Generator \$30K
 - Cap/Opamps/Switches/ECL Logic \$2K
 - VMIC \$18K
- Total \$70.2K



NLC LLRF

RF Monitor Costs

*Next Linear
Collider*

- Hardware
 - Splitters (need 12) \$1600
 - Down Converter Mixers (need 100) \$400
 - IQ Mixers (need 100) \$500
 - Amplifier 10W 11.424GHz \$7500
 - Cable Plant \$125K
 - Diodes (need 100) \$500
 - Couplers \$2K
 - VME Digitizers (10MHz/100MHz) \$4500
 - High Speed digitizers \$24K
 - MUX \$12K
 - VME Crate \$5K
 - VME CPU \$5K
- Total \$600K



4-Pack LLRF Monitor Hardware Cost

*Next Linear
Collider*

Splitters	1600	5	8000
mixers	400	40	16000
IQ mixers	500	40	20000
Amp	7500	1	7500
Cable	1250	40	50000
Diodes	500	40	20000
Couplers	200	40	8000
VME Dig	4500	3	13500
Dig High	24000	1	24000
Mux	12000	2	24000
Vme Crate	5000	1	5000
VME CPU	5000	1	5000
TOTAL			201000



Cost Estimates for Hardware

*Next Linear
Collider*

- LLRF Detection (100 signals) \$600K
- LLRF Modulation scheme \$170K
- 4-Pack Analog Option Additional \$201K*
- 3 LLRF EMI/RFI Racks (Mario Ortega Cost Est.)
- Total \$770K

* Not included in Total



Man-Power Costs

*Next Linear
Collider*

- Hardware (Engineering) \$125K
 - **Timing Distribution Module (IF FREE)**
 - **IQ Modulator** Elias Andrikopoulos
 - **IQA Modules** Andrew Young
 - **Sample/Hold Modules** (Engineer)
- Software (Code Development) \$82K
- Software (Test/Database) \$110K
- Technician \$112K
 - (Boni Cordova-Grimaldi, Greg Dalit, Bob Noriega, Hunter Technologies, Jennifer Russell, Young Kim)
- System integration \$110K
- Total \$564K
- **GRAND TOTAL** \$1.34M